



SHED ROOF OPTION



GABLE ROOF OPTION



By using these standard plans, the user agrees to release the Cities of Springfield and Eugene from any and all claims, liabilities, suits and demands on account of any injury, damage or loss to persons or property, including any injury or death, or economic losses, arising out of the use of these construction documents. The use of these plans does not eliminate or reduce the user's responsibility to verify any and all information herein. No warranty is implied or provided.

By using these standard plans, the user agrees to release the Cities of Springfield and Eugene from any and all claims, liabilities, suits and demands on account of any injury, damage or loss to persons or property, including any injury or death, or economic losses, arising out of the use of these construction documents. The use of these plans does not eliminate or reduce the user's responsibility to verify any and all information herein. No warranty is implied or provided.

**-SPRINGFIELD DEVELOPMENT CODE:**

Clear and Objective Standards: A detached accessory dwelling unit may be approved under Type 1 procedure if it meets the following design standards:

- (a) Only non-reflective siding and roofing materials are allowed.
- (b) Minimum roof pitch is 3 in 12.
- (c) Eaves must project from the accessory dwelling unit at least 1 foot on all elevations.
- (d) The primary entry must have a covered or roofed entrance with a minimum depth and width of 3 feet.

REVIEWED FOR CODE  
COMPLIANCE

Site Plan 00

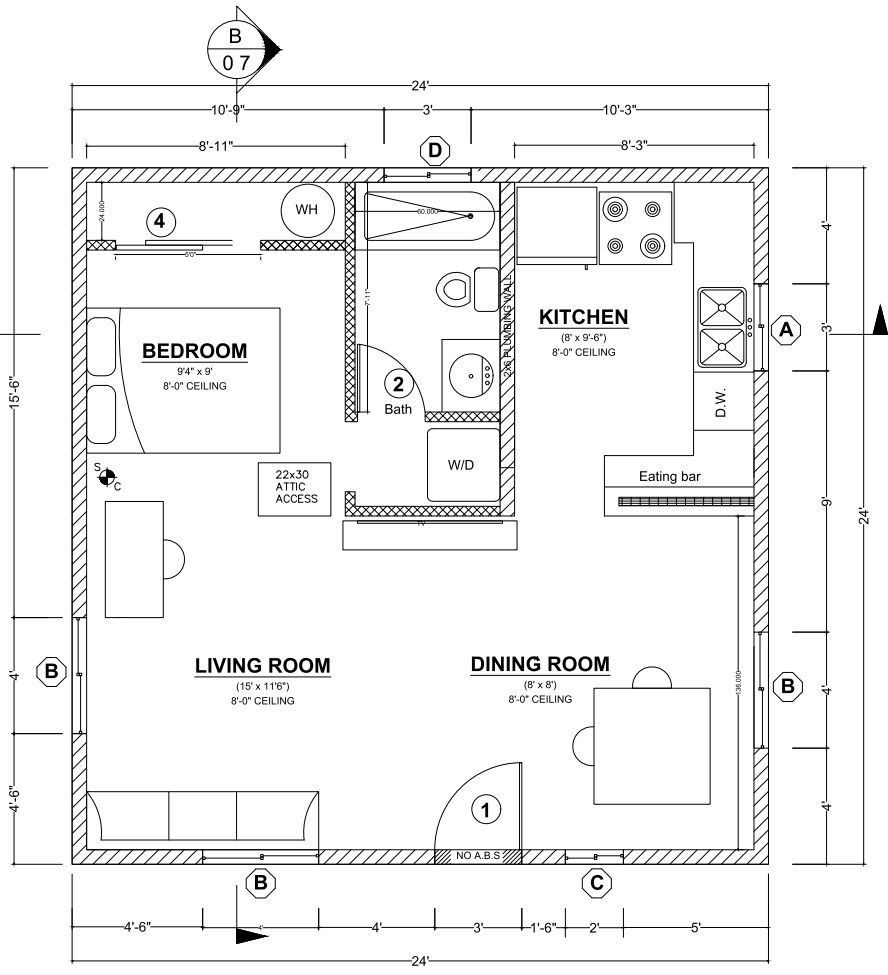

**FLOOR PLAN NOTES**

- Exterior walls located less than 3 feet from a property line must be 1-hour fire-resistance rated, with no openings allowed. [R302.1]
- Permanent heating facilities capable of maintaining a room temperature of not less than 68°F shall be provided. Portable space heaters shall not be used to meet this requirement. [R303.10]
- Habitable rooms shall have a floor area of not less than 70 square feet and not less than 7 feet in any horizontal dimension. [R304]
- Habitable rooms and hallways shall have a minimum 7-foot ceiling height. Bathrooms and laundry rooms shall have a ceiling height of not less than 6 feet 8 inches. Refer to R305 for sloped ceiling allowances.
- Tempered or other safety glazing complying with the impact test requirements of R 308.3 must be installed in hazardous locations identified in R308.4, including:
  - glazing in doors;
  - glazing in the plane of a door where the glazing is within 24" of the door
  - glazing in a wall perpendicular to a door where the glazing is within 24" of the hinge side of an in-swinging door.
  - glazing that is greater than 9 square feet in area and within 36" horizontally from a walking surface, if the bottom edge is less than 18" above the floor and the top edge is more than 36" above the floor.
  - glazing in guards and railings.
  - glazing in tub/shower walls or enclosures where the glazing is less than 60" above the standing surface and within 60" horizontally of the edge of the tub or shower.
- Every sleeping room shall have not less than one operable emergency egress opening [R310.1]. Emergency egress openings shall have a net clear opening of not less than 5.7 sq. ft. The net clear opening height shall be not less than 24" and the net clear opening width shall be not less than 20" [R310.2.1 See Exceptions]. Minimum sill height for egress openings shall not exceed 44" [R310.2.2].
- A landing is required on the exterior side of the exterior egress door [R311.3]. The width of the landing shall not be less than the door served and the dimension in the direction of travel not be less than 36". The landing shall be not more than 1 1/2" below the top of the threshold if the door swings out over the landing. The landing shall be not more than 8" below the top of the threshold if the door does not swing over the landing [R311.3.1].
- Smoke and Carbon Monoxide Alarms. [R314 and R315]
  - Smoke alarms listed in accordance with UL 217 shall be installed in each bedroom and out side of each separate sleeping area in the immediate vicinity of the bedrooms.
  - Smoke alarms shall be hard-wired with battery backup. Multiple smoke detectors shall be interconnected so that activation of one alarm will activate all alarms.
  - Smoke alarms must be installed in accordance with the manufacturer's instructions and shall be located to comply with the following:
    - At least 3 feet horizontally from a door to a bathroom containing a tub or shower.
    - Ionization smoke alarm with alarm-silencing switch: at least 10 feet horizontally from permanent cooking appliance.
    - Ionization smoke alarm w/o alarm-silencing switch: at least 20 feet horizontally from permanent cooking appliance.
    - Photoelectric smoke alarm: at least 6 feet horizontally from permanent cooking appliance.
- All rooms containing a tub and/or shower shall be provided with an 80 cfm minimum exhaust fan controlled by a dehumidistat timer or similar means of automatic control. The exhaust air must be discharged outside of the building. [R303.3] [M1505.5]
- Minimum shower compartment area: 1,024 sq. in.; shall also be capable of encompassing a 30" circle. [OPSC 408.6].
- Showers shall be equipped with control valves of the pressure balance, thermostatic mixing or the combination pressure balance/thermostatic mixing valve type with maximum mixed water setting of 120 degrees Fahrenheit. [OPSC 408.3].
- Water heaters shall be anchored to resist horizontal movement. (i.e. earthquake strapping) [M1307.2, OPSC 507.2] 59
- Combustion air is required for solid fuel burning appliances, per manufacturer's instructions. [M1701.1]
- Range exhaust installation per manufactures installation instruction.
- A whole-house mechanical ventilatio system must be provided. The whole-house ventilation system must be balanced (exhaust air equal to make-up air). [R303.4 and M1505.4]

Whole House ventilation system proposed:  
 \_\_\_ HRV or ERV  
 \_\_\_ Other (describe) \_\_\_\_\_

**WALL LEGEND**

- 2x6 WALL
- 2x4 WALL
- 2x4 PONY WALL

**WINDOW SCHEDULE**

MARK	DIMENSION	TYPE	TEMPERED	NOTES
(A)	3'-0" x 3'-0"	SLIDING		
(B)	4'-0" x 4'-0"	SLIDING		
(C)	2'-0" x 4'-0"	FIXED	Y	
(D)	3'-0" x 1'-0"	SLIDING		

Exterior windows shall be tested by an approved independent laboratory and bear a label identifying the manufacturer, thermal performance including the U-factor and approved inspection agency to indicate compliance with AAMA/WDMA/CSA 101/ I.s.2/A440. [R609.3; N1104.4.1]

Labels shall remain attached to the windows until the building inspector inspects and verifies the labeling. [N1104.4.1]

**DOOR SCHEDULE**

MARK	DIMENSION	TYPE	TEMPERED	NOTES
(1)	3'-0" x 6'-8"	SWINGING		1-3/8" SOLID CORE
(2)	2'-8" x 6'-8"	SWINGING		
(3)		BI-FOLD		LAUNDRY ROOM
(4)	5'-0" x 6'-8"	SLIDING		5FT CLOSET

Floor Plan

576SF ACCESSORY DWELLING UNIT

Sheet Number

By using these standard plans, the user agrees to release the Cities of Springfield and Eugene from any and all claims, liabilities, suits and demands on account of any injury, damage or loss to persons or property, including any injury or death, or economic losses, arising out of the use of these construction documents. The use of these plans does not eliminate or reduce the user's responsibility to verify any and all information herein. No warranty is implied or provided.

**A02**

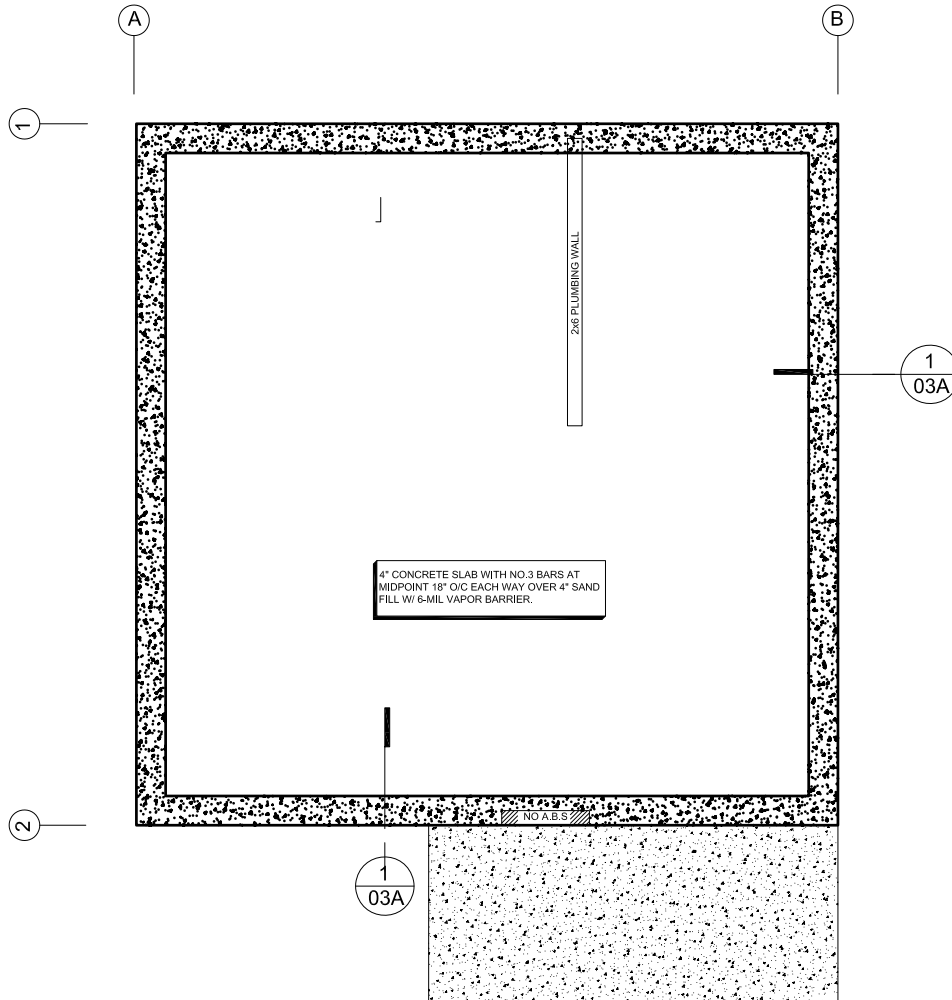

4" CONCRETE SLAB WITH NO.3 BARS AT MIDPOINT 18" O/C EACH WAY OVER 4" SAND FILL W/ 6-MIL VAPOR BARRIER.

CONCRETE LANDING  
(SEE FLOOR PLAN NOTE #7)

Scale: 1/2" = 1Ft

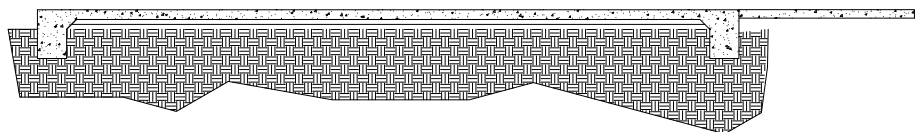

Left

Scale: 1/2" = 1Ft

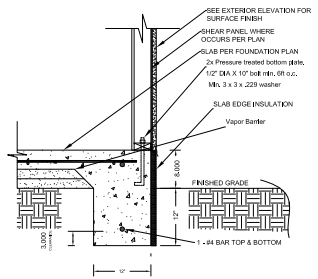

DETAIL 1  
(NTS)

FOUNDATION PLAN NOTES

1. ALL ANCHORS BOLTS SHALL BE 1/2" DIAMETER AND HAVE A MINIMUM EMBEDMENT OF 7 INCHES INTO CONCRETE (UND) AND NOT SPACED MORE THAN 6 FEET APART (R403.1.6)
2. 3"x3"x.229" PLATE WASHERS SHALL BE USED ON EACH SILL PLATE ANCHOR BOLT (R602.11.1)
3. HOLE IN PLATE WASHER MAY BE DIAGONALLY SLOTTED WITH MAXIMUM 4" LARGER WIDTH THAN BOLT DIAMETER AND MAXIMUM 1-3/4" SLOT LENGTH (R602.11.1)
4. PROVIDE A MINIMUM OF TWO ANCHOR BOLTS PER SILL PLATE WITH ONE BOLT LOCATED MAXIMUM 12" AND MINIMUM 7 BOLT DIAMETERS FROM EACH END OF EACH SECTION (R403.1.6)
5. BOLTS MUST BE LOCATED IN THE MIDDLE THIRD OF THE SILL PLATE WIDTH (R403.1.6)
6. FASTENERS FOR PRESSURE-PRESERVATIVE TREATED AND FIRE RETARDANT TREATED WOOD SHALL BE HOT-DIPPED ZINC COATED GALVANIZED, STAINLESS STEEL OR COPPER (R517.3)
7. A 6-MIL POLYETHYLENE OR APPROVED VAPOR RETARDER JOINTS LAPPED 12" MIN REQUIRED UNDER THE FLOOR SLAB. (R506.2.3)
8. INSULATION EXPOSED TO THE EXTERIOR SHALL BE PROTECTED FROM PHYSICAL AND SOLAR DAMAGE. (N1104.2.3)
9. PROVIDE (1) 2" X 10" SCREENED FOUNDATION VENT WITHIN 3 FEET OF EACH CORNER FOR UNDER FLOOR VENTILATION (R409.1)
10. PROVIDE POSITIVE CONNECTION BETWEEN POSTS AND BEAMS TO PREVENT LATERAL DISPLACEMENT IN ACCORDANCE WITH FIGURE R502.9
11. CRAWL SPACE ACCESS REQUIRED PER R409.4

Foundation- Slab on Grade

576SF ACCESSORY DWELLING UNIT

A03

By using these standard plans, the user agrees to release the Cities of Springfield and Eugene from any and all claims, liabilities, suits and demands on account of any injury, damage or loss to persons or property, including any injury or death, or economic losses, arising out of the use of these construction documents. The use of these plans does not eliminate or reduce the user's responsibility to verify any and all information herein. No warranty is implied or provided.

**FOUNDATION PLAN NOTES**

1. ALL ANCHOR BOLTS SHALL BE 1/2" DIAMETER AND HAVE A MINIMUM EMBEDMENT OF 7" INCHES INTO CONCRETE (ING) AND NOT SPACED MORE THAN 6 FEET APART (R403.1.6)
2. 3"x3"x0.226" PLATE WASHERS SHALL BE USED ON EACH SILL PLATE ANCHOR BOLT. (R602.11.1)
3. HOLE IN PLATE WASHER MAY BE DIAGONALLY SLOTTED WITH MAXIMUM 8" LARGER WIDTH THAN BOLT DIAMETER AND MAXIMUM 1-3/4" SLOT LENGTH (R602.11.1)
4. PROVIDE A MINIMUM OF TWO ANCHOR BOLTS PER SILL PLATE WITH ONE BOLT LOCATED MAXIMUM 12" AND MINIMUM 7 BOLT DIAMETERS FROM EACH END OF EACH SECTION. (R403.1.6)
5. BOLTS MUST BE LOCATED IN THE MIDDLE THIRD OF THE SILL PLATE WIDTH (R403.1.6)
6. FASTENERS FOR PRESSURE-PRESERVATIVE TREATED AND FIRE RETARDANT TREATED WOOD SHALL BE HOT-DIP GALVANIZED, STAINLESS STEEL OR COPPER. (R317.3)
7. A 5-MIL POLYETHYLENE OR APPROVED VAPOR RETARDER JOINTS LAPPED 12" MIN REQUIRED UNDER THE FLOOR SLAB. (R506.2.3)
8. INSULATION EXPOSED TO THE EXTERIOR SHALL BE PROTECTED FROM PHYSICAL AND SOLAR DAMAGE. (I1106.2.3)
9. PROVIDE (1) 8" X 18" SCREENED FOUNDATION VENT WITHIN 3 FEET OF EACH CORNER FOR UNDER FLOOR VENTILATION. (R408.1)
10. PROVIDE POSITIVE CONNECTION BETWEEN POSTS AND BEAMS TO PREVENT LATERAL DISPLACEMENT IN ACCORDANCE WITH FIGURE R502.9
11. CRAWL SPACE ACCESS REQUIRED PER R408.4

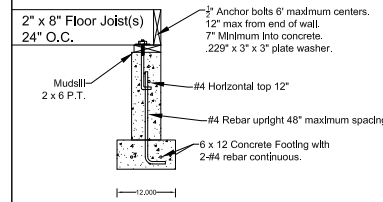

**DETAIL 1**  
(NTS)

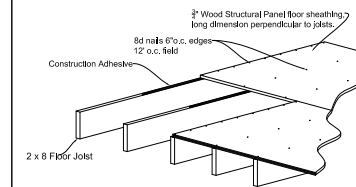

**SUB-FLOOR INSTALLATION**

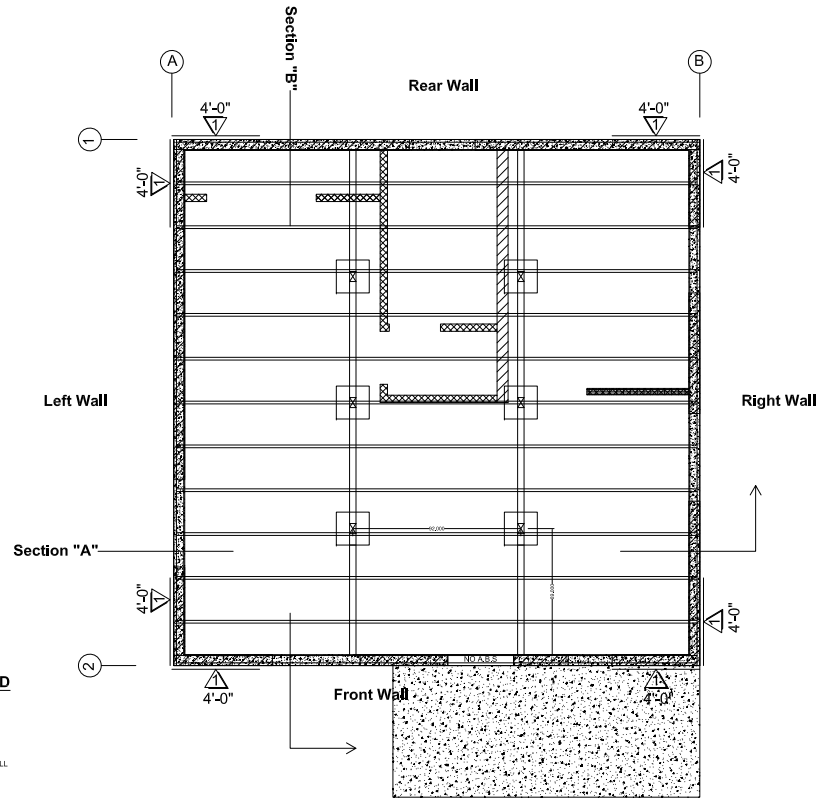

- WALL LEGEND**
- 2x6 WALL
  - 2x4 WALL
  - 2x4 PONY WALL

Scale: 3/8" = 1 FT

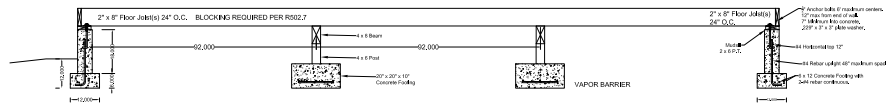

**Section View "A"**

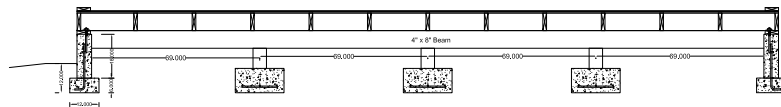

**Section View "B"**

Scale: 1/2" = 1 FT

By using these standard plans, the user agrees to release the Cities of Springfield and Eugene from any and all claims, liabilities, suits and demands on account of any injury, damage or loss to persons or property, including any injury or death, or economic losses, arising out of the use of these construction documents. The use of these plans does not eliminate or reduce the user's responsibility to verify any and all information herein. No warranty is implied or provided.

**A03.1**

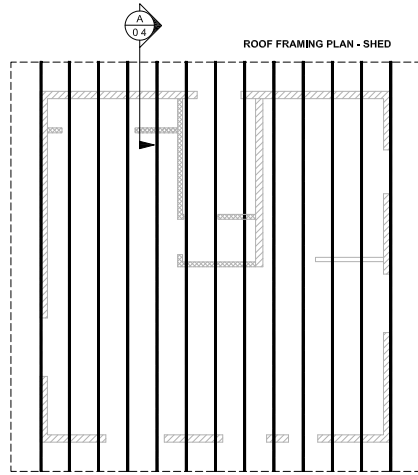

11 7/8" TJI's @ 16" o.c. w/ R-38 high-density fiberglass batt Insul (10.25" thick)

ROOF PLAN / TRUSS LAYOUT  $\frac{1}{4}'' = 1'0''$

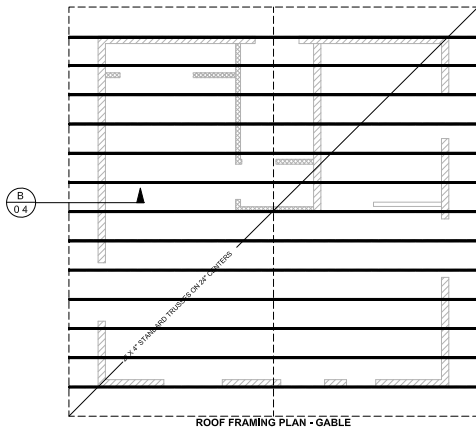

ROOF FRAMING PLAN - GABLE

**ATTIC VENTILATION REQUIRED**

NET FREE CROSS VENTILATION AREA =  $\frac{1}{300}$   
 VENT AREA REQ'D =  $600 \text{ ft}^2 / 300 = 2 \text{ ft}^2 \times 144 = 288 \text{ In}^2$

**GABLE END VENTS**  
 NFVA =  $71 \text{ In}^2$   
 QTY = 2 VENTS  
 VENT AREA PROVIDED =  $2 \times 71 \text{ In}^2 = 142 \text{ In}^2$

**EAVE VENTS**  
 NFVA:  $23 \text{ In}^2$   
 QTY = 8 VENTS  
 VENT AREA PROVIDED =  $8 \times 23 \text{ In}^2 = 184 \text{ In}^2$

**TOTAL VENT AREA PROVIDED**  
 $(142 \text{ In}^2) + (184 \text{ In}^2) = 326 \text{ In}^2 > 288 \text{ In}^2$

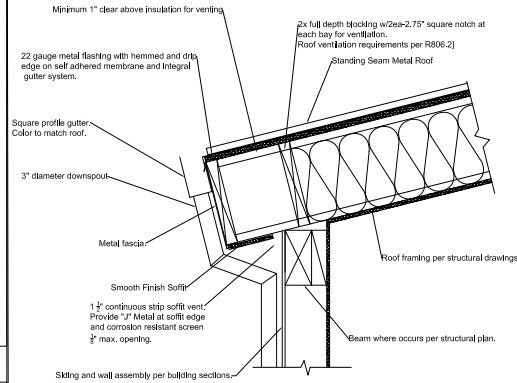

Detail A/04

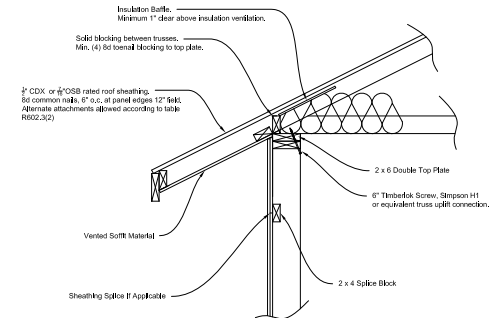

Truss Bearing on 2x6 Exterior Wall With Vented Soffits

Detail B/04

**TRUSS FRAMING NOTES**

- TRUSS DESIGN DRAWING SHALL BE ON THE JOB SITE AND AVAILABLE TO THE BUILDING INSPECTOR AT THE FRAMING INSPECTION (R602.16.1)
- TRUSSES SHALL BE BRACED IN ACCORDANCE WITH THE TRUSS DESIGN DRAWINGS (R602.16.3)
- TRUSSES SHALL BE ATTACHED TO SUPPORTING WALLS BY CONNECTIONS CAPABLE OF RESISTING UPLIFT FORCES AS SPECIFIED ON THE TRUSS DESIGN DRAWINGS (R602.11.1.1)
- A 22" X 30" MINIMUM ATTIC ACCESS OPENING IS REQUIRED. (R607)

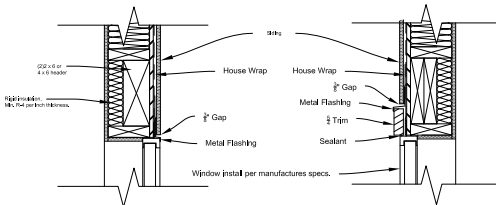
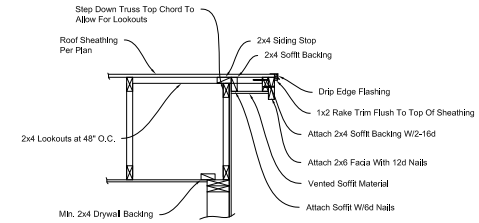

Window Head Flashing

Window Head Flashing With Trim

By using these standard plans, the user agrees to release the Cities of Springfield and Eugene from any and all claims, liabilities, suits and demands on account of any injury, damage or loss to persons or property, including any injury or death, or economic losses, arising out of the use of these construction documents. The use of these plans does not eliminate or reduce the user's responsibility to verify any and all information herein. No warranty is implied or provided.

# Wall Bracing Plan

576SF ACCESSORY DWELLING UNIT

Sheet Number

# A05

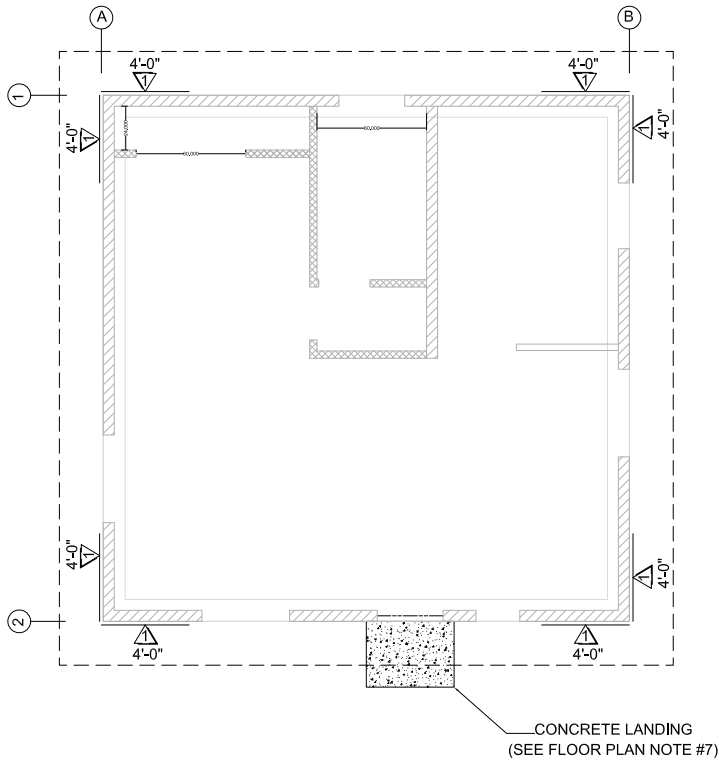

NOTE: ROOF SHEATHING TO BE 5/8" APA RATED SHEATHING 24x0 AT 6" O/C EDGE NAILING AND 12" O/C FIELD NAILING

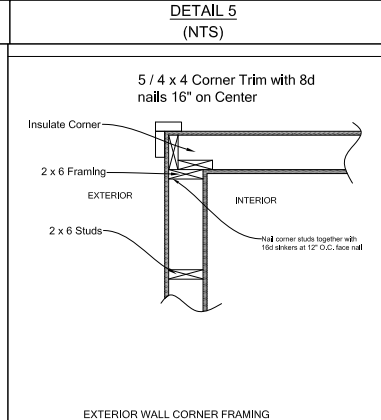
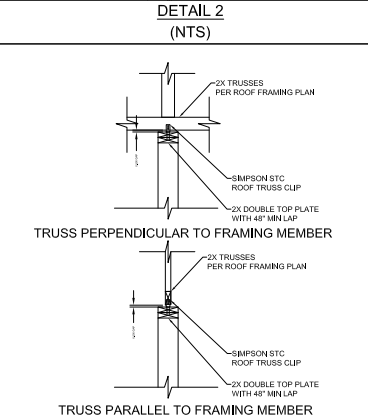
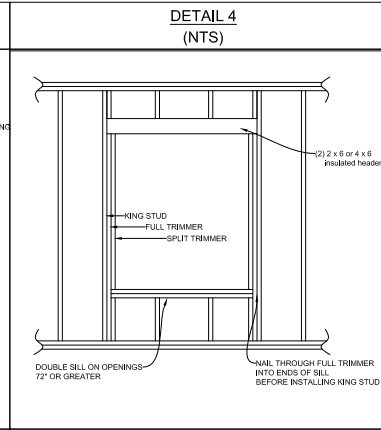
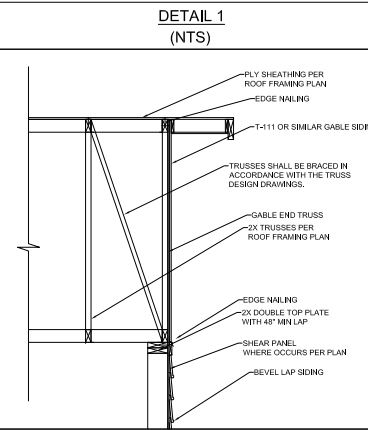
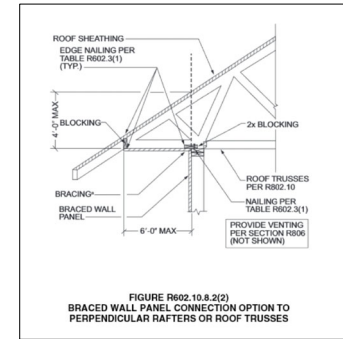
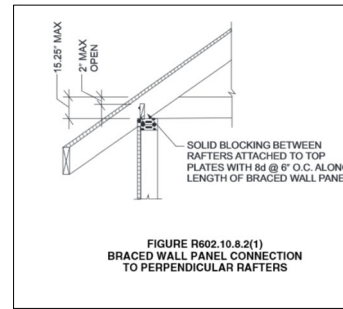

WOOD STRUCTURAL PANEL SHEATHING							
MARK	MINIMUM NAIL		MINIMUM WOOD STRUCTURAL PANEL SPAN RATING	MINIMUM NOMINAL PANEL THICKNESS (in)	MAXIMUM WALL STUD SPACING (in)	PANEL NAIL SPACING	
	SIZE	PENETRATION (in)				EDGES (Inches o/c)	FIELD (Inches o/c)
⚠	6D COMMON	1.5	24:0	5/8"	16	6	12
	8D COMMON	1.75	24:16	3/4"	16	6	12

WOOD STRUCTURAL PANELS SHALL CONFORM TO DOC. PS 1, DOC. PS 2 OR ANSI/APA PRP 210, CSA O437 OR CSA O325. PANELS SHALL BE IDENTIFIED BY A GRADE MARK OR CERTIFICATE OF INSPECTION ISSUED BY AN APPROVED AGENCY.

VERTICAL JOINTS OF PANEL SHEATHING SHALL OCCUR OVER AND BE FASTENED TO COMMON STUDS.

HORIZONTAL JOINTS IN BRACED WALL PANELS SHALL OCCUR OVER AND BE FASTENED TO COMMON BLOCKING OF A MINIMUM 1 1/2 INCH THICKNESS.

### LEGEND

# BRACED WALL LINE

By using these standard plans, the user agrees to release the Cities of Springfield and Eugene from any and all claims, liabilities, suits and demands on account of any injury, damage or loss to persons or property, including any injury or death, or economic losses, arising out of the use of these construction documents. The use of these plans does not eliminate or reduce the user's responsibility to verify any and all information herein. No warranty is implied or provided.

ELEVATION KEY NOTES

1. ROOF MATERIAL: \_\_\_\_\_
2. EXTERIOR WALL COVERING \_\_\_\_\_
3. A WATER RESISTIVE BARRIER THAT MEETS THE 75% DRAINAGE EFFICIENCY REQUIREMENTS OF ASTM E2273 OR OTHER MEANS OF DRAINAGE COMPLYING WITH R703.1.1 SHALL BE PROVIDED BEHIND THE EXTERIOR SIDING, CLADDING OR VENEER.
4. EXTERIOR WALL COVERINGS SHALL BE SECURELY FASTENED WITH ALUMINUM, GALVANIZED, STAINLESS STEEL OR RUST PREVENTATIVE COATED NAILS OR STAPLES IN ACCORDANCE WITH TABLE R703.3(1) OR WITH OTHER APPROVED CORROSION-RESISTANT FASTENERS IN ACCORDANCE WITH THE WALL COVERING MANUFACTURER'S INSTALLATION INSTRUCTIONS. [R703.3.2]
5. CORROSION-RESISTANT FLASHING SHALL BE INSTALLED AT WINDOW AND DOOR OPENINGS AND ABOVE ALL PROJECTING WOOD TRIM. FLASHING SHALL BE APPLIED SHINGLE-FASHION IN A MANNER TO PREVENT ENTRY OF WATER INTO WALL CAVITY OR PENETRATION OF WATER TO THE BUILDING STRUCTURAL FRAMING COMPONENTS. THE FLASHING SHALL EXTEND TO THE SURFACE OF THE EXTERIOR WALL FINISH. [R703.4]
6. ENCLOSED ATTICS AND RAFTER SPACES SHALL BE PROVIDED WITH CROSS VENTILATION. NET VENTILATING AREA SHALL BE NOT LESS THAN 1/150TH OF THE AREA OF THE SPACE VENTILATED. WHERE EAVE VENTS ARE INSTALLED, INSULATION SHALL NOT BLOCK THE FREE FLOW OF AIR. PROVIDE A 1" MINIMUM AIR SPACE ABOVE INSULATION AND BAFFLE AT EAVE OR SOFFIT VENTS. [R806]

By using these standard plans, the user agrees to release the Cities of Springfield and Eugene from any and all claims, liabilities, suits and demands on account of any injury, damage or loss to persons or property, including any injury or death, or economic losses, arising out of the use of these construction documents. The use of these plans does not eliminate or reduce the user's responsibility to verify any and all information herein. No warranty is implied or provided.

**A06**

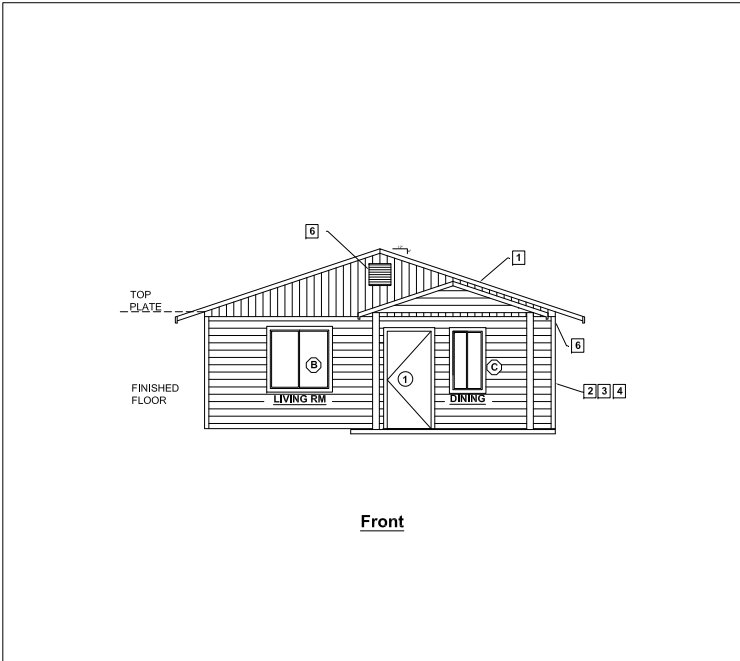

Front

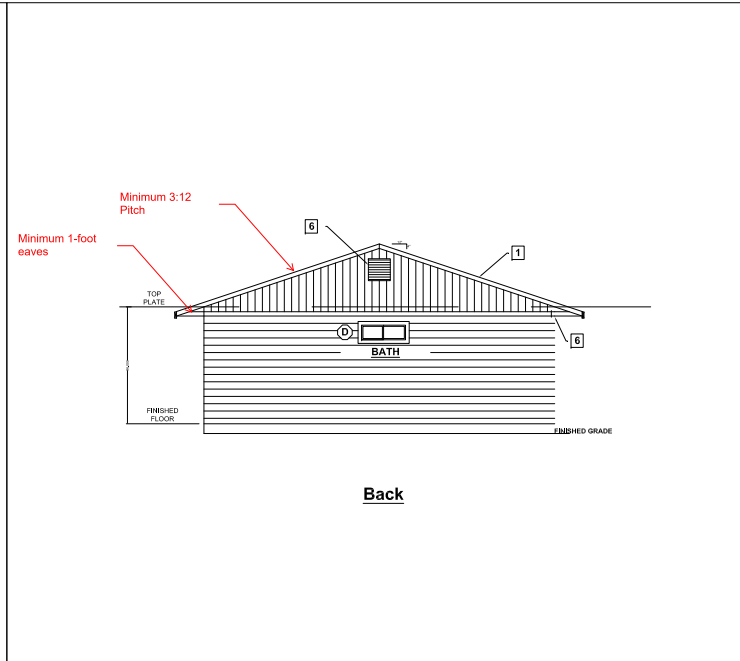

Back

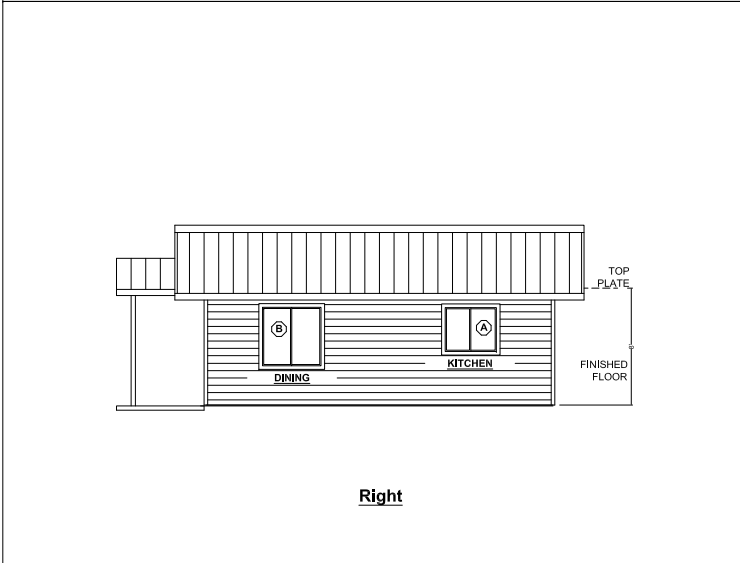

Right

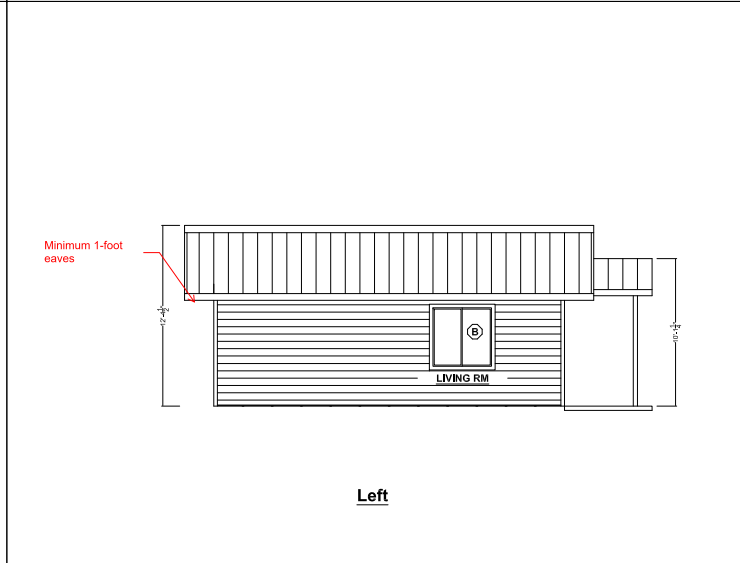

Left

SCALE: 1/4" = 1'



# Elevation - Shed Roof

576SF ACCESSORY DWELLING UNIT

Sheet Number

## ELEVATION KEY NOTES

1. ROOF MATERIAL: \_\_\_\_\_
2. EXTERIOR WALL COVERING \_\_\_\_\_
3. A WATER RESISTIVE BARRIER THAT MEETS THE 75% DRAINAGE EFFICIENCY REQUIREMENTS OF ASTM E273 OR OTHER MEANS OF DRAINAGE COMPLYING WITH R703.1.1 SHALL BE PROVIDED BEHIND THE EXTERIOR SIDING, CLADDING OR VENEER.
4. EXTERIOR WALL COVERINGS SHALL BE SECURELY FASTENED WITH ALUMINUM, GALVANIZED, STAINLESS STEEL OR RUST PREVENTATIVE COATED NAILS OR STAPLES IN ACCORDANCE WITH TABLE R703.3(1) OR WITH OTHER APPROVED CORROSION-RESISTANT FASTENERS IN ACCORDANCE WITH THE WALL COVERING MANUFACTURER'S INSTALLATION INSTRUCTIONS. [R703.3.2]
5. CORROSION-RESISTANT FLASHING SHALL BE INSTALLED AT WINDOW AND DOOR OPENINGS AND ABOVE ALL PROJECTING WOOD TRIM. FLASHING SHALL BE APPLIED SHINGLE-FASHION IN A MANNER TO PREVENT ENTRY OF WATER INTO WALL CAVITY OR PENETRATION OF WATER TO THE BUILDING STRUCTURAL FRAMING COMPONENTS. THE FLASHING SHALL EXTEND TO THE SURFACE OF THE EXTERIOR WALL FINISH. [R703.4]
6. ENCLOSED ATTICS AND RAFTER SPACES SHALL BE PROVIDED WITH CROSS VENTILATION. NET VENTILATING AREA SHALL BE NOT LESS THAN 1/150TH OF THE AREA OF THE SPACE VENTILATED, WHERE EAVE VENTS ARE INSTALLED. INSULATION SHALL NOT BLOCK THE FREE FLOW OF AIR. PROVIDE A 1" MINIMUM AIR SPACE ABOVE INSULATION AND BAFFLE AT EAVE OR SOFFIT VENTS. [R806]



**Front**

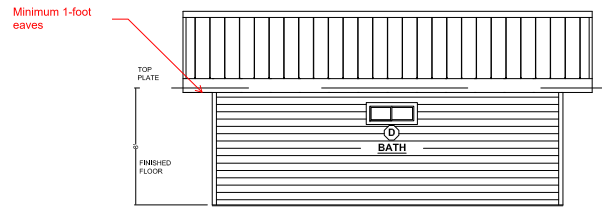

**Back**

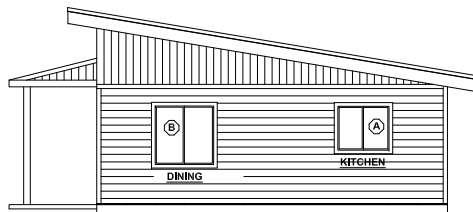

**Right**

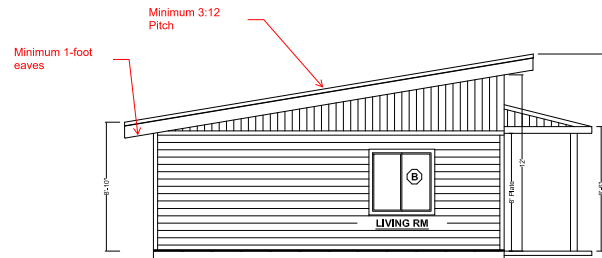

**Left**

SCALE: 1/4" = 1'

By using these standard plans, the user agrees to release the Cities of Springfield and Eugene from any and all claims, liabilities, suits and demands on account of any injury, damage or loss to persons or property, including any injury or death, or economic losses, arising out of the use of these construction documents. The use of these plans does not eliminate or reduce the user's responsibility to verify any and all information herein. No warranty is implied or provided.

**A061**

ROOF/CEILING CONSTRUCTION:  
 3/4" CDX OR 5/8" OSB SHEATHING  
 ENGINEERED TRUSSES @ 24" ON CENTER,  
 R-49 BLOWN IN INSULATION  
 1/2" GYPSUM BOARD

FOR EAVE DETAILS SEE SHEET 04

TYPICAL WALL CONSTRUCTION:  
 LAP SIDING OVER WATER RESISTIVE BARRIER  
 1/2" CDX OR 7/16" OSB SHEATHING  
 2 X 6 #2 STUDS 16" ON CENTER  
 INTERMEDIATE FRAMING  
 (2) 2 X 6 OR 4 X 6 HEADER AT WINDOW AND DOOR OPENINGS  
 R-21 INSULATION  
 1/2" GYPSUM BOARD

CONC. SLAB AND FTG'S  
 PER PLAN

R-15 SLAB EDGE  
 (TYP.)

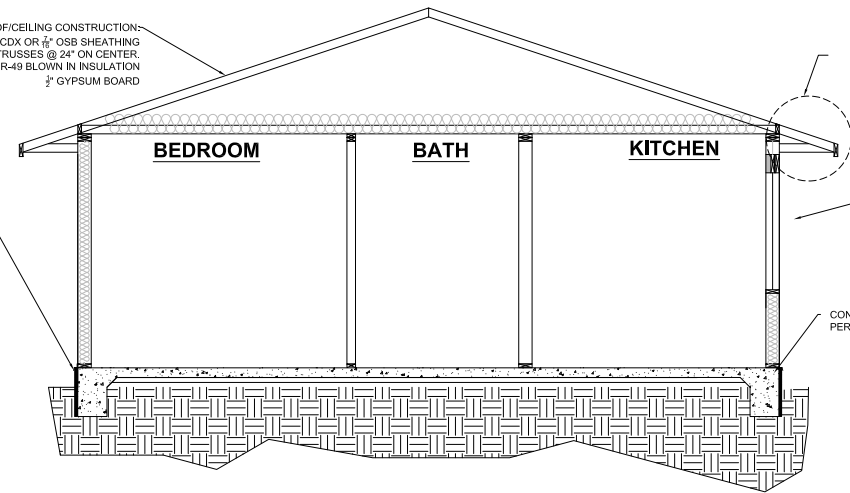

**Section A/07**

SECTIONS  
 1/2" = 1'-0"

Prescriptive Envelope Requirements<sup>a</sup>

Building Element	Insulation R-value <sup>b</sup> or component U-factor	Required performance
Wall -above grade	R-21, Intermediate framing <sup>c</sup>	U-0.059 <sup>d</sup>
Flat ceiling <sup>e</sup>	R-49	U-0.021
Vaulted ceiling <sup>f</sup>	R-30 Rafter or R-30A' Scissor truss	U-0.033
Underfloor	R-30	U-0.033
Slab edge	R-15	F-0.520
Windows	U-0.30	U-0.30
Doors <sup>gh</sup>	U-0.20	U-0.20
Skylights	U-0.50	U-0.50

- The thermal performance of a component may be adjusted as allowed in N1104.1. Calculations to document equivalent heat loss shall be performed using the procedure and approved U-factors contained in Table N1104.1(1).
- R-values used in this table are nominal for the insulation only in standard wood framed construction and not for the entire assembly.
- Intermediate Framing with insulated headers in accordance with N1104.5.2.
- R-49 insulation installed to minimum 6-inches depth at top plate at exterior of structure to achieve U-factor.
- Vaulted ceiling surface area exceeding 50 percent of the total heated space floor area shall have a U-factor no greater than U-0.026 (equivalent to R-38 rafter or scissor truss with R-38 advanced framing).
- A = Advanced frame construction. See Section N1104.6.
- Sliding glass doors shall comply with window performance requirements.
- A maximum of 28 square feet of exterior door area can have a U-factor of 0.54 or less.

Sections - Gable

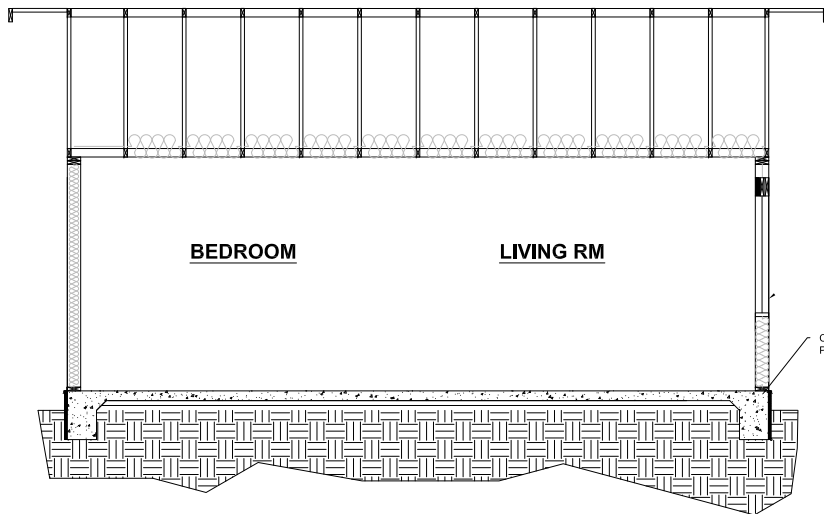

CONC. SLAB AND FTG'S  
 PER PLAN

**Section B/07**

SECTIONS  
 1/2" = 1'-0"

Section A: Envelope Enhancement Measure, Table N1101.1(2) (Select One)

- 1 High Efficiency Walls:
  - Exterior walls: U-0.045 / R-21 cavity insulation + R-5 continuous
- 2 Upgraded Features:
  - Exterior walls: U-0.057 / R-23 intermediate OR R-21 advanced, and
  - Framed floors: U-0.026 / R-38, and
  - Windows: U-0.28 (average UA)
- 3 Upgraded Features:
  - Exterior walls: U-0.055 / R-23 intermediate OR R-21 advanced, and
  - Flat ceiling: U-0.017 / R-60, and
  - Framed floors: U-0.026 / R-38
- 4 Super Insulated Windows and Attic OR Framed Floors:
  - Windows: U-0.22 (Triple Pane Low-e, and
  - Flat ceiling: U-0.017 / R-60, or
  - Framed floors: U-0.026 / R-38
- 5 Air Sealing Home and Ducts (cannot be combined with measure B)
  - Mandatory air sealing of all wall coverings at top plate and air sealing checklist, and
  - Mechanical whole-building ventilation system with rates meeting M1503 or ASHRAE 62.2, and
  - All ducts and air handlers contained within building envelope, OR
  - All ducts sealed with mastic
- 6 High Efficiency Thermal Envelope UA
  - Proposed UA is 8% lower than the code UA

Section B: Conservation Measure, Table N1101.1(2) (Select One)

- A High Efficiency HVAC System:
  - Gas-fired furnace or boiler AUE 94%, OR
  - Air source heat pump HSPF 9.5 / 15.0 SEER cooling, OR
  - Ground source heat pump COP 3.5 or Energy Star rated
- B Ducted HVAC Systems Within Conditioned Space: (cannot be combined with Measure 5)
  - All ducts and air handlers contained within building envelope
- C Ductless Heat Pumps:
  - Ductless heat pump HSPF 10.0 in primary zone of dwelling
- D High Efficiency Water Heater:
  - Natural gas / propane water heater with UEF 0.85, OR
  - Electric heat pump water heater Tier 1 Northern Climate Specification Product

By using these standard plans, the user agrees to release the Cities of Springfield and Eugene from any and all claims, liabilities, suits and demands on account of any injury, damage or loss to persons or property, including any injury or death, or economic losses, arising out of the use of these construction documents. The use of these plans does not eliminate or reduce the user's responsibility to verify any and all information herein. No warranty is implied or provided.

576SF ACCESSORY DWELLING UNIT

Sheet Number

**A07**