

RFQ # 1847 Municipal Security Jail Padded Project

April 10, 2017

Supplier,

You are receiving this email as you have been identified as one who may have an interest in responding to our Request for Quote RFQ# 1847.

The City of Springfield Development and Public Works Department is soliciting bids for Security Cell Padding Project.

This solicitation is for City of Springfield Development and Public Works Department. The successful bidder will be required to enter into a City Contract (sample attached) and provide a [certificate of liability insurance](#) naming the City as an additional insured. The RFQ packet has been posted to the [City website](#) RFP/ITB Page. All information regarding the RFQ will be posted online. (If the hyperlink doesn't work for you please navigate to www.springfield-or.gov on the left hand side look for the Purchasing/Contracts link.)

If you intend to bid, and/or if you have any questions regarding the bid items or process, the deadline to respond is EOD 4/18/17.

Bids are due Tuesday 4/25/17 by 5:00 pm PST either mailed via USPS, UPS, Fed Ex, or Email to:

Jim Polston, Development and Public Works Department, City of Springfield 225 5th Street Springfield, OR 97477. No faxed bids will be accepted. **No late bids will be accepted.**

Bid packets must include the items listed below:

1. Completed and signed bid form
2. Exhibit B Acceptance of Contract terms and conditions and ability to comply with insurance requirements
3. Exhibit C Completed MWESB Form
4. Warranty information

City reserves the right to reject any or all bids and to waive irregularities and informalities in the selection process. The City further reserves the right to negotiate, amend, and refine bids in consultation with one or more of the prospective bidders.

All material submitted by the bidders shall be considered property of City, and City shall not be required to return same to any bidder. The material submitted by bidder will be treated in the same manner as City's own records.

The City of Springfield is not liable for any costs incurred by vendors for the preparation and presentation of their bids. This includes any costs in the submission of a bid or in making necessary studies or designs for the preparation thereof.

All bids become part of the public record and are available for public review unless exempt under Oregon Public Records Law. Bidders wishing to exempt appropriate portions of their bids from disclosure as public records are encouraged to discuss their concerns with City's Finance Director (address listed below) prior to the submissions of their Bids.

Bob Duey, Finance Director
City of Springfield Finance Department
225 Fifth Street
Springfield, OR 97477

If you have any questions regarding the RFQ after reading the document posted please contact me via email. **Any contact with any other City employee regarding this RFQ# 1847 or the process will be grounds for disqualification.**

Project Lead

Jim Polston, Associate Project Manager
City of Springfield
225 Fifth Street
Springfield, OR 97477
541-726-3652 (office)
541-225-8840 (cell)
541-726-2309 (fax)
jpolston@springfield-or.gov

Thanks,

Jim Polston





**Statement of Work
Request for Quote**

(For Intermediate solicitations between \$10,000 and \$99,999)

RFQ# 1847

DUE DATE: Quotes will be received by Jim Polston, Development and Public Works Department, 225 5th Street, Springfield OR 97477 until 5:00 pm, April 25, 2017.

Late bids will not be accepted.

All questions should be addressed via email to jpolston@springfield-or.gov

Name of Company

Contact Person

DEVELOPMENT AND PUBLIC WORKS - Padded Holding Cell Project

The City of Springfield Development and Public Works Department is seeking qualified firms to supply and install correctional grade padding in an existing holding cell at the Springfield Municipal Jail. The room named "J1200" is approximately 6' x 12'-0" x 10'-0" in height (See RFQ 1847 Exhibit A Plans & Pics). Gold Medal Safety Padding (or Equal) is to be installed on the walls, interior side of the room door and door frame and the floor. Padding shall be detailed to meet any vision light, cameras, and food pass in the door.

PROJECT DESCRIPTION:

Furnish, deliver and install Gold Medal Safety Padding to one (1) room at the Springfield Oregon Municipal Jail. The room named "J1200" is approximately 6' x 12'-0" x 10'-0" in height (See RFQ 1847 Exhibit A Plans & Pics). Padding is to be installed on the walls, interior side of the room door and door frame and the floor. Padding shall be detailed to meet any cameras, vision light and food pass in the door. The existing plumbing fixture, existing wall mirrors, handicap grab bars, and existing strobe lights shall be removed by others and are NIC. Modifications to the existing room door to install a vision light and food pass shall be by others before the installation of the Gold Medal Safety Padding.

Codes and Standards:

- A. All work shall be furnished, constructed and installed to conform with any applicable codes, statutes or standards that apply to this type.
 1. 2014 Oregon Structural Specialty code.
 2. Any applicable Federal, State, or City of Springfield Codes, Standards and Ordinances, including these contract documents.
 3. Any items of work required by the above codes and standards but not specifically shown or mentioned shall be provided without additional cost.
 4. Contractor is responsible for acquiring and paying for any and all permits and scheduling and passing any necessary inspections

CELL PADDING

A. Acceptable Product; subject to compliance to specified requirements: Marathon Engineering Corp., Gold Medal Resilient Padding (or approved equal)

B. Characteristics:

1. Types:
 - a. Walls and Doors: Manufacturer's synthetic resinous material in prefabricated sheets bonded to oriented strand board.
 - b. Floors: Manufacturer's pourable, self-leveling synthetic resinous material.
2. Padding thickness: 1" (25 mm) nominal for walls and doors; 1/2" (13 mm) nominal for floors.
3. Material Properties:
 - a. Weight: 5 lbs. per sq. ft. (25 kg/ m², approximate.
 - b. Hardness Range: 45-50 Shore A-2 when tested in accordance with ASTM D2240.
 - c. Temperature Stability: Resilience unaffected from 35 to 120°F (2° to 49°C).
 - d. Elongation: Minimum 150% at break when tested in accordance with ASTM D412.
 - e. Fungus Resistance: Complete and inherent within material.
 - f. Oil Resistance: Less than 5% volume swell when tested in accordance with ASTM D471.
 - g. Fire Hazard Classification: Meeting Class A when tested in accordance with ASTM E84.
4. Bond Coat: Manufacturer's standard type compatible with padding material.
5. Finish topcoating: Manufacturer's scuff-resistant standard color finish coat.

C. Filler material: Padding manufacturers liquid filler material as recommended for filling joints and fastener holes.

D. Fasteners: All stainless steel. Types as recommended by padding manufacturer for securing vertical panels to substrates indicated.

INSTALLATION

- A. Install cell padding materials in accordance with manufacturer's product data and final reviewed and accepted shop drawings (provided by contractor to City for approval).
- B. Attach prefabricated wall and door padding panels to vertical substrates using specified fasteners. Install wall padding positioned to allow 3/16" (5 mm) joint gap between panels. Fabricate padding for doors to exact fit in single continuous panels without seams.
- C. Padding shall be detailed to meet any cameras, vision lights, food passes and adjacent grades in the cell. Padding shall be shaped and coated to provide smooth transitions where needed.
- D. Fill joints and fastener holes with manufacturer's liquid filler material and allow to cure. After material has cured, sand filled joints and holes flush with adjacent surfaces.
- E. Upon completion of sanding work, remove dust and debris from surfaces and clean floor substrates for application of pourable padding material.
- F. Pour liquid floor padding material to prepared substrates to provide a smooth, uniform, level surface. Allow flooring to cure before permitting traffic onto surfaces and application of finish topcoating.
- G. Apply finish topcoating to installed padding in full uniform coverage over entire surface. Completed application shall show no evidence of application patterns, thin spots, imperfections or irregularities.
- H. Install repair padding in existing padded cell J1215 at newly installed pie flap, at the abandoned camera location and at damaged areas particularly at the door frame. Match manufacturers instructions for repairs.
- I. Extra Materials: Provide for Owner's maintenance use additional cell padding materials of quantities required to patch a minimum 15 square foot area of installation.
 1. Furnish materials in manufacturer's original unopened packaging or containers with labels intact and legible with proper identification.
 2. Store materials at locations as directed by Owner.
 3. Include written instructions with materials directing the use and recommended procedures for repairing installed padding.

Note: "Brand Name or Equal Specification" means a specification that uses one or more manufacturers' names, catalog numbers, or similar identifying characteristics to describe the standard of quality, performance, functionality or other characteristics needed to meet the contracting agency's requirements. Such a specification authorizes bidders or proposers to offer goods or services that are equivalent or superior to those brands named or described in the specifications. The City shall determine if the proposed substitution is equal or superior based on submittals given to us during the proposal process. All contractors will be notified of the "equal or superior substitution" prior to submitting their proposals, allowing everyone to bid the approved alternate product if desired.

Item #	Requirements or Specifications	Quantity	Unit	Total Cost
1.0	Furnish and install cell padding as specified	1	Lump Sum	
2.0	Repair padding at pie flap and door frame of room	10	Sq.Ft	
3.0	Extra Material	1	Lump Sum	
License Information				
License #	Type of License, name of Issuing Authority	Expiration Date		
Prior Experience				
Name of Customer	Description and \$ Value of Project	Ph. #	Contact Name	

Special Instructions:

Valid for 90 Days from date submitted below.
 Signer acknowledges that they have the legal authority to bind entity.
 Signer acknowledges that they have read and accept the terms and conditions of the contract and can meet the insurance requirements.
 If this is a BOLI project signer acknowledges that they quoted using BOLI wages.
 Unless otherwise specified, all items quoted are to be new, unused and not remanufactured in any way.
 Proposer must clearly identify all products quoted. Brand name and model or number must be shown.
 CITY reserves the right to make the award by item, groups of items or entire quote, whichever is in the best interest of CITY.
 CITY may reject any Quote not in compliance with the RFQ, attachments, and addenda, or if it is in the best interest of CITY.

Submitted this _____ day of _____ 20_____

Signature of Proposer

Print Proposer Name

Title of Proposer

Proposer Address

Proposer Phone #

Proposer Email Address

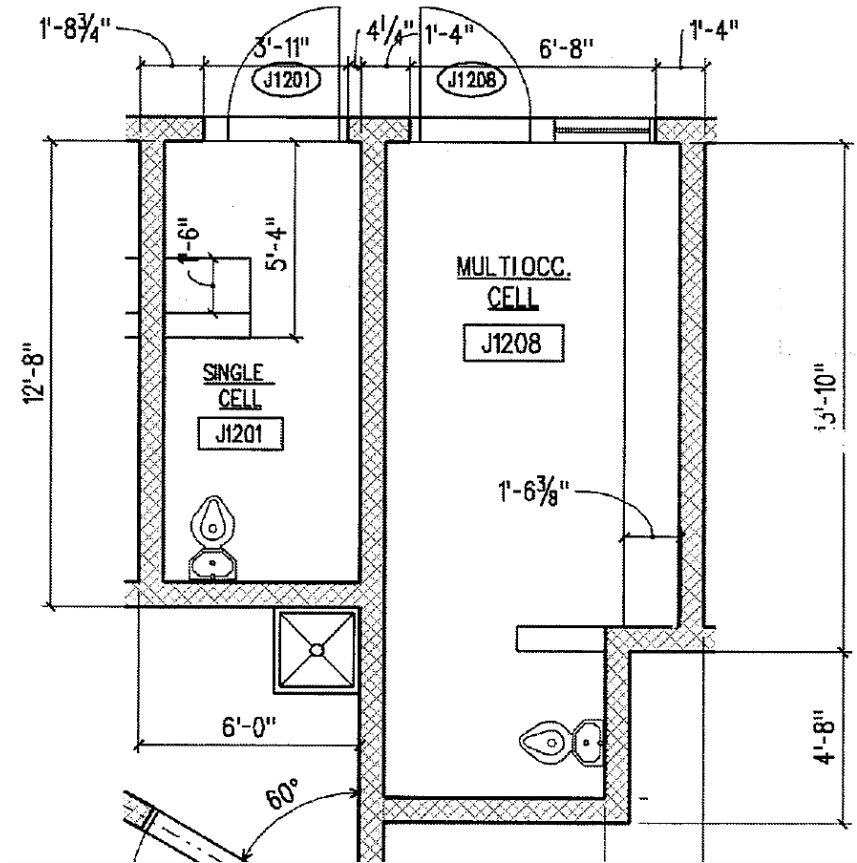
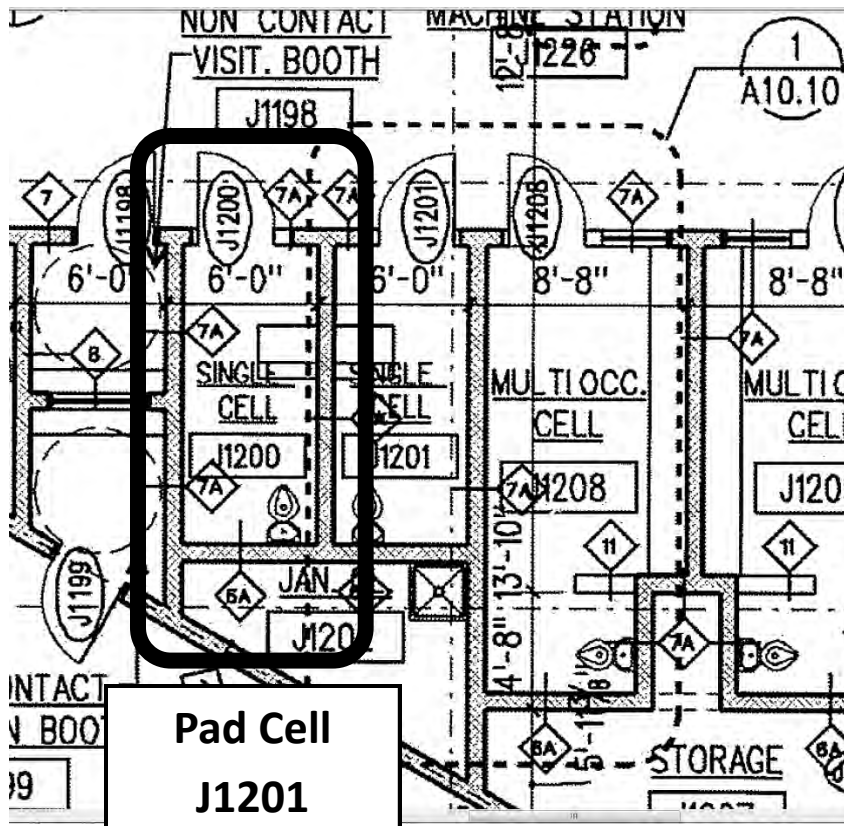

**Close up of Cell J1201,
a mirror image of J1200**

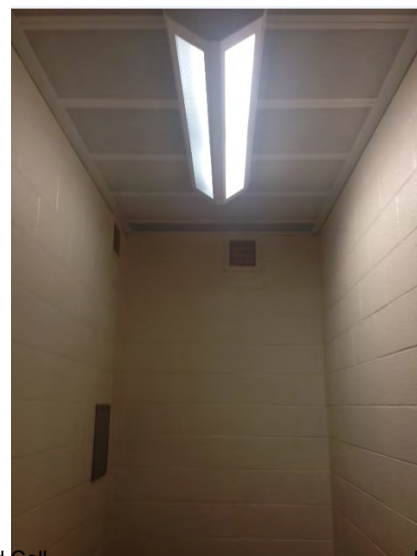

Note:

Room will be ready for installation. Seat wall and plumbing will be removed prior to padding installation.

No Padding installed on ceiling.

Photos of Cell J1201

**CITY OF SPRINGFIELD
INDEPENDENT CONTRACTOR AGREEMENT**

(Type 1: For Public Works Contracts under \$50,000 that are not Public Improvement Projects)
Contract # **Call 3708 for contract #**

Dated:

Parties: City of Springfield ("CITY")
A municipal corporation in the State of Oregon
225 Fifth Street
Springfield, Oregon 97477

and

("Independent Contractor")

Additional Independent Contractor Information:

- A. Type of Entity: Sole Proprietorship Partnership Limited Liability Company Corporation
- B. Address:
- C. Telephone:
- D. Fax No:
- E. Fed. I.D. No:
- F. Construction Contractor Board No:
- G. Foreign Contractor: Yes No
(Foreign means not domiciled in or registered to do business in Oregon) See Exhibit B (11).

City Account Number(s) To Be Charged (Include Percentages):

Account Number	Percentage

In consideration of the mutual covenants contained herein, the parties agree to the following terms, provisions and conditions:

1. **Payment by CITY.** CITY shall pay Independent Contractor according to the sum and schedule described in Attachment 1 attached hereto and incorporated herein by this reference and in an amount not to exceed _____.
2. **Invoice.** Invoice to be sent to: Accounts Payable - City of Springfield, 225 5th Street, Springfield, OR 97477 or email to ap@springfield-or.gov. Invoice will be paid on net 30 day terms upon City acceptance of goods delivered, work or services performed. The invoice must reference this contract #XXX and approval code #XXX.
3. **Services to be Performed by Independent Contractor.** Independent Contractor shall perform the services described in Attachment 1.

4. **Term.** This Agreement is effective as of the date first set forth above and shall continue until _____, unless earlier terminated in accordance with the provisions of this Agreement or by mutual consent of the parties.
5. **Sourcing.** *[Insert here a description the sourcing activity that was performed.]*
6. **First Point of Contact.**
Independent Contractor: [insert name, ph# and email address]
CITY: [insert name, ph# and email address]
7. **Independent Contractor Status.** By its execution of this Agreement, Independent Contractor certifies its status as an "Independent Contractor" as that term is used under the laws of the State of Oregon, and that all performance of any labor or services required to be performed by Independent Contractor under the terms of this Agreement shall be performed in accordance with the standards set forth in ORS 670.600, and as more specifically set forth on Exhibit "A" attached hereto and incorporated herein by this reference.
8. **Conformance with Oregon Public Contracts Law (ORS Chapter 279).** Independent Contractor shall comply with all applicable provisions of Oregon law for public contracts, including, but not limited to ORS 279B.110, ORS 279B.220, ORS 279B.225, ORS 279B.230 and ORS 279B.235, and as more fully set forth on Exhibits "A", "B" and "C" attached hereto and incorporated herein by this reference.
9. **Work Performed.** The work to be performed by Independent Contractor includes services generally performed by Independent Contractor in his/her/its usual line of business.
10. **Warranty.** Independent Contractor will warranty all workmanship for 1 (one) year from acceptance of the work.
11. **Tax duties and Liabilities.** Independent Contractor shall be responsible for all federal, state and local taxes, if any, applicable to any payments received pursuant to this Agreement, including but not limited to income tax, payroll tax, social security and self-employment tax. CITY shall not withhold, pay, or in any other manner be responsible for payment of any taxes on behalf of Independent Contractor and as more specifically set forth in Exhibit C.
12. **Reimbursement of Expenses.** Independent Contractor shall not be entitled to reimbursement by CITY for any expenses incurred by Independent Contractor unless otherwise agreed in writing.
13. **Materials and Supplies.** Independent Contractor shall supply all materials and supplies needed to perform the services required unless otherwise agreed in writing.
14. **No Authority to Bind CITY.** Independent Contractor shall have no authority to enter into contracts on behalf of CITY, it's officers, agents and employees. This Agreement shall not create a partnership or joint venture of any sort between the parties.
15. **Federal Employment Status.** In the event payment made pursuant to this Agreement is to be charged against federal funds, Independent Contractor hereby certifies that it is not currently employed by the Federal Government and the amount charged does not exceed Independent Contractor's normal charge for the type of services provided.
16. **Indemnification and Hold Harmless.** Independent Contractor shall defend, indemnify and hold harmless City from and against all liability or loss and against all claims or actions based upon or arising out of damage or injury to persons or property caused by or sustained in connection with the performance of this Contract by Independent Contractor except, pursuant to ORS 30.140, for losses, claims, or actions resulting from the sole negligence of City.

The Independent Contractor shall assume all responsibilities for the work, and bear all losses and damages directly or indirectly resulting to the Independent Contractor, the City, or to others on account of the character or performance of the work, unforeseen difficulties, accidents, or any other cause whatsoever. The Independent Contractor shall assume defense of, indemnify and save harmless the City, its officials, agents, and employees from all claims, liability, loss, damage and injury of every kind, nature and description, directly or indirectly resulting from activities in the performance of the Contract, the ownership, maintenance or use of motor vehicles in connection therewith, or the acts, omissions, operations, or conduct of the Independent Contractor or any Subcontractor under the Contract or any way arising out of the Contract, irrespective of whether any act, omission or conduct of the City connected with the Contract is a condition or contributory cause of the claim, liability loss, damage or injury and irrespective of whether act, omission, or conduct of the Independent Contractor or Subcontractor is merely a condition rather than a cause of a claim, liability, loss damage or injury. The Independent Contractor shall not be liable for nor be required to defend or indemnify, the City relative to claims for damage or damages resulting solely from acts or omissions of the City, its officials, agents or employees. The absence of or inadequacy of the liability insurance required in section 17 shall not negate Independent Contractor's obligations in this paragraph.

17. Insurance.

- 17.1. General Insurance.** The Independent Contractor shall maintain in force for the duration of this Agreement a Commercial General Liability insurance policy written on an occurrence basis with limits not less than \$2,000,000 per occurrence and \$3,000,000 in the aggregate for bodily injury or property damage. The policy will contain a "per project" aggregate endorsement. Automobile Liability (owned, non-owned and hired) insurance with limits not less than \$1,000,000 per occurrence shall be maintained. The City, its employees, officials and agents will be named as an Additional Insured where operations are being conducted related to this contract, on the General Liability policy as respects to work or services performed under this Agreement to the extent that the death or bodily injury to persons or damage to property arises out of the fault of the Independent Contractor or the fault of the Independent Contractor's agents, representatives or subcontractors. This insurance will be primary over any insurance the City may carry on its own. If the City requires Professional Liability coverage, the City's Risk Manager must approve the terms, conditions and limits. Independent Contractor understands that CITY is a public entity subject to the requirements of the Oregon Governmental Tort Claims Act, ORS 30.260 et seq. In the event that CITY'S financial obligations or liabilities are modified by any amendment to the liability limits imposed by the Oregon Governmental Tort Claims Act, Independent Contractor agrees that the limits regarding liability insurance set forth in this Section 17 will be modified to conform to such limits. Independent Contractor and CITY shall sign an amendment to this Agreement incorporating such modification.
- 17.2. Asbestos Abatement.** (Only applicable to contracts where asbestos maybe present) The Commercial General Liability policy shall be written on a form that meets the following criteria and must be ASBESTOS SPECIFIC as follows:
- a. A full occurrence form, or
 - b. A limited occurrence form with at least a three-year (3) tail, or
 - c. A claim made form with a three-year (3) tail.
- 17.3. Workers' Compensation.** Independent Contractor shall provide and maintain workers' compensation coverage with limits not less than \$500,000 for its employees, officers, agents, or partners, as required by applicable workers' compensation laws as defined in ORS 656.027 and ORS 701.035(5). If Independent Contractor is exempt from coverage, a written statement signed by Independent Contractor.
- 17.4. Course of Construction and/or Installation Floater.** The Independent Contractor shall maintain an all risk insurance policy covering the replacement cost of the work during the course of construction. The policy shall include the interests of the City and architect and the first two layers of sub-contractors. The amount of insurance shall equal the completed value of the contract. The City, at its option, may elect to supply this coverage.

- 17.5. Evidence of Insurance Coverage.** Evidence of the required insurance coverages issued by an insurance company satisfactory to the City shall be provided to the City by way of a City approved certificate of insurance before any work or services commence.
- 17.6. Notice of Cancellation or Material Change in Coverage.** The certificate of insurance shall contain a requirement that the Insurance company notify the City 30 days prior to any cancellation or material change in coverage. If the approved insurance company will not provide this 30 day notice, the Independent Contractor shall provide written notice to the City contract manager within 2 calendar days after the Independent Contractor becomes aware that their coverage has been canceled or has been materially changed. The Independent Contractor shall either fax 541-726-3782 said notice or email it directly to Bob Duey (rduey@springfield-or.gov), Finance Director at the City. Regardless of what circumstances caused Independent Contractors insurance coverage to cease or be modified, it is the Independent Contractor's responsibility to notify the City. Failure to maintain proper insurance or provide notice of cancellation or modification shall be grounds for immediate termination of this contract. _____ **(Independent Contractor initials)**
- 17.7. Equipment and Material.** The Independent Contractor shall be responsible for any loss, damage, or destruction of its own property, equipment, and materials used in conjunction with the work.
- 17.8. Subcontractors.** The Independent Contractor shall require all subcontractors to provide and maintain general liability, auto liability, professional liability (as applicable), and workers' compensation insurance with coverage's equivalent to those required of the general contractor in this contract. The Independent Contractor shall require certificates of insurance from all subcontractors as evidence of coverage.
- 17.9. Exception or Waivers.** Any exception or waiver of these requirements shall be subject to review and approval from the City's Risk Manager.
- 17.10. Railroad Protective Liability Coverage.** If work being performed under this agreement is near railroad tracks or a railroad right of way and the Railroad requires special insurance (for example: Railroad Protective Liability Coverage) Independent Contractor will be responsible for meeting the Railroad insurance requirements before any work commences. Any insurance required to be purchased by the Railroad is in addition to the insurance required by the City.
- 18. Termination.** The performance of work under this Agreement may be terminated by CITY, in whole or in part, whenever for any reason CITY shall determine that such termination is in the best interest of CITY. Any such termination shall be effected by delivery to the Independent Contractor of a Notice of Termination specifying the extent to which performance of the work under the Agreement is terminated and the date on which such termination is effective. Upon delivery to the Independent Contractor of a Notice of Termination under this paragraph, the Independent Contractor and CITY shall, by agreement, make an appropriate written modification to this Agreement governing completion of portions of the Independent Contractor's work and payment therefore by CITY.
- 19. Rights in Data.** All original written material, including programs, card decks, tapes, listings, and other documentation originated and prepared for CITY pursuant to this Agreement, shall become exclusively the property of CITY. The ideas, concepts, know-how, or techniques developed during the course of this Agreement by Independent Contractor personnel can be used by either party in any way it may deem appropriate. Material already in Independent Contractor's possession, independently developed by Independent Contractor outside the scope of this Agreement, or rightfully obtained by Independent Contractor from third parties, shall belong to Independent Contractor. This agreement shall not preclude Independent Contractor from developing materials which are competitive, irrespective of their similarity to materials which might be delivered to CITY pursuant to this Agreement. Independent Contractor shall not, however, use any written materials developed under this Agreement in developing materials for others, except as provided in this section.
- 20. Confidentiality.** During the course of performance hereunder, Independent Contractor or its agent, employees, or contractors, may receive confidential information. Independent Contractor agrees to use its best efforts to maintain the confidentiality of such information and to inform each agent and employee performing services of the confidentiality obligation that pertains to such information.

21. **Assignment/Subcontract.** Independent Contractor shall not assign, sell, transfer, subcontract or sublet rights, or delegate responsibilities under this agreement, in whole or in part, without the prior written approval of CITY. No such written approval shall relieve Independent Contractor of any obligations of this Agreement, and any transferee or subcontractor shall be considered the agent of Independent Contractor. Independent Contractor shall remain liable as between the original parties to this Agreement as if no such assignment had occurred.
22. **Successors in Interest.** The provisions of this Agreement shall be binding upon and shall inure to the benefit of the parties to this Agreement and their respective successors and assigns.
23. **Compliance with All Government Regulations.** Independent Contractor shall comply with all Federal, State and local laws, codes, regulations and ordinances applicable to the work performed under this Agreement. Failure to comply with such requirements shall constitute a breach of contract and shall be grounds for termination of this Agreement. Damages or costs resulting from noncompliance shall be the sole responsibility of Independent Contractor.
24. **Attorney Fees.** In the event a lawsuit of any kind is instituted on behalf of CITY to enforce any provision of this Agreement, Independent Contractor shall pay such additional sums as the Court may adjudge reasonable for attorney fees plus all costs and disbursements at trial and on any appeal.
25. **Force Majeure.** Neither party to this Agreement shall be held responsible for delay or default caused by fire, riot, acts of God and/or war which is beyond that party's reasonable control. CITY may terminate this Agreement upon written notice after determining such delay or default will unreasonably prevent successful performance of the Agreement.
26. **Assistance Regarding Patent And Copyright Infringement.** In the event of any claim or suit against CITY on account of any alleged patent or copyright infringement arising out of the performance of this Agreement or out of the use of any material furnished or work or services performed hereunder, Independent Contractor shall defend CITY against any such suit or claim and hold CITY harmless from any and all expenses, court costs, and attorney's fees in connection with such claim or suit.
27. **Severability.** If any provision of this Agreement is declared by a court to be illegal or in conflict with any law, the validity of the remaining terms and provisions shall not be affected; and the rights and obligations of the parties shall be construed and enforced as if the Agreement did not contain the particular provision held to be invalid.
28. **Access to Records.** CITY and its duly authorized representatives shall have access to books, documents, papers and records of Independent Contractor which are directly pertinent to this Agreement for the purpose of making audit, examination, excerpts and transcripts.
29. **Waiver.** Failure of CITY to enforce any provision of this Agreement shall not constitute a waiver or relinquishment by CITY of the right to such performance in the future nor of the right to enforce any other provision of this Agreement.
30. **Amendments.** The terms of this Agreement shall not be waived, altered, modified, supplemented or amended in any manner whatsoever, without prior written approval of CITY. No modification of this Agreement shall bind either party unless reduced to writing and subscribed by both parties, or ordered by a Court.
31. **Nondiscrimination.** Independent Contractor shall comply with all applicable requirements of Federal and State civil rights and rehabilitation statutes, rules and regulations.
32. **Dual Payment.** Independent Contractor shall not be compensated for work performed under this contract from any CITY agency other than the agency which is a party to this contract.

- 33. **Choice of Law, Forum, Construction of Agreement.** This Agreement shall be governed and construed in accordance with the laws of the State of Oregon, apart from choice of law provisions. The parties agree that the Circuit Court for the County of Lane, State of Oregon, or the Federal District Court of the State of Oregon (Eugene) is the sole and proper forum for resolving any disputes involving this Agreement, any breach of this Agreement, or relating to its subject matter. The Parties agree to submit themselves to the jurisdiction of such courts without challenge to the jurisdiction of these courts. This Agreement shall not be construed more favorably to CITY due to the preparation of this Agreement by CITY. The headings and subheadings in this Agreement are for convenience, do not form a part of this Agreement, and shall not be used in construing this Agreement.
- 34. **Entire Agreement.** This Agreement signed by both parties is the parties' final and entire Agreement and supersedes all prior and contemporaneous oral or written communications between the parties, their agents and representatives. There are no representations, promises, terms, conditions or obligations other than those contained herein.

IN WITNESS WHEREOF the parties have executed this Agreement to be effective the date first set forth above.

CITY OF SPRINGFIELD:

INDEPENDENT CONTRACTOR:

By: _____
 Name: _____
 Title: _____
 Date: _____

By: _____
 Name: _____
 Title: _____
 Date: _____

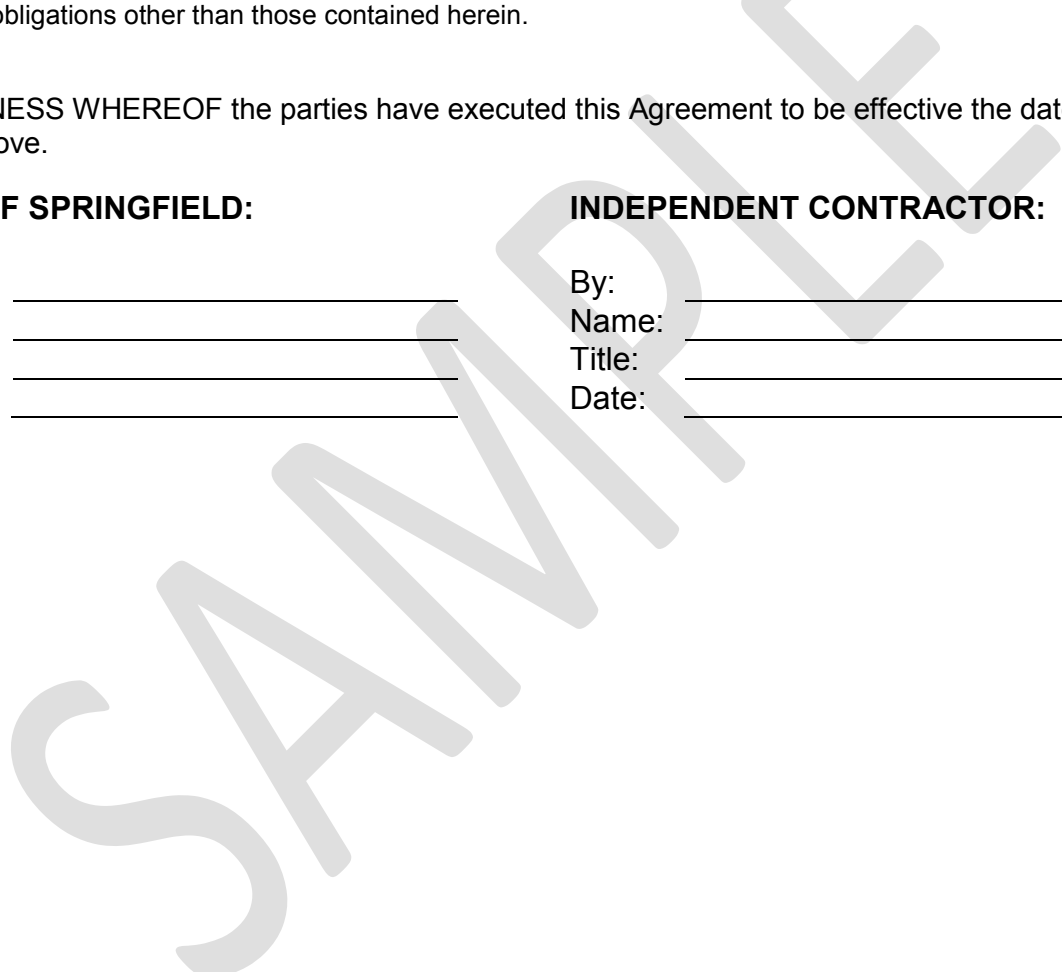

EXHIBIT "A"

INDEPENDENT CONTRACTOR STATUS

Independent contractor states and represents that contractor is an independent contractor as that term is defined in Oregon Revised Statute 670.600 and more specifically represents, states and agrees that in providing the services and scope of work specified in this contract:

1. Independent contractor provides services for remuneration; and
2. Independent contractor is free from direction and control over the means and manner of providing the services and scope of work subject only to the right of City to specify the desired results; and
3. Independent contractor is customarily engaged in an independently established business; and
4. Independent contractor is licensed within the state of Oregon to provide any services for which a license is required under ORS Chapter 671 or 701 and is responsible for obtaining other licenses or certificates necessary to provide the service or scope of work; and
5. Independent contractor complies with at least five of the following requirements:
 - (a) A business location is maintained that is separate from the business or work location of City; or is in a portion of the independent contractor's residence and that portion is used primarily for the business.
 - (b) The independent contractor bears the risk of loss related to the provision of services or scope of work such as entering into a fixed price contract, defective work is required to be corrected, the services provided are warranted or indemnification agreements, liability insurance and performance bonds and errors and omissions insurance are provided.
 - (c) Contracted services for two or more different persons or entities within a twelve month period have been obtained, or routinely engaged in business advertising, solicitation, or other marketing efforts reasonably calculated to obtain new contracts to provide similar services.
 - (d) Significant investment in the business has been made such as purchasing tools or equipment, paying for premises or facilities where services are provided, paying for licenses, certificates or specialized training.
 - (e) Possesses authority to hire other persons to assist in providing their services and has the authority to fire those persons.
6. Independent contractor will immediately inform City in the event that it fails to conduct its services in one or more particulars as represented in 1 through 5 above.

EXHIBIT "B"

**City of Springfield
Public Contracts
Conformance with Oregon Public Contractors Laws**

Pursuant to Oregon law, every public contract shall contain the following conditions:

- 1) Make payment promptly, as due, to all persons supplying to the contractor labor or material for the performance of the work provided for in the contract. ORS 279B.220(1)
- 2) Pay all contributions or amounts due the Industrial Accident Fund from the contractor or subcontractor incurred in the performance of the contract. ORS 279B.220(2).
- 3) Not permit any lien or claim to be filed or prosecuted against the state or a county, school district, municipality, municipal corporation or subdivision thereof, on account of any labor or material furnished. ORS 279B.220(3).
- 4) Pay to the Department of Revenue all sums withheld from employees under ORS 316.167. ORS 279B.220(4).
- 5) If the agreement is for lawn and landscape maintenance, it shall contain a condition requiring the contractor to salvage, recycle, compost or mulch yard waste material at an approved site, if feasible and cost-effective. ORS 279B.225.
- 6) Promptly, as due, make payment to any person, copartnership, association or corporation furnishing medical, surgical and hospital care services or other needed care and attention, incident to sickness or injury, to the employees of the contractor, of all sums that the contractor agrees to pay for the services and all moneys and sums that the contractor collected or deducted from the wages of employees under any law, contract or agreement for the purpose of providing or paying for the services. All employers shall comply with ORS 656.017. ORS 279B.230.
- 7) A person may not be employed for more than 10 hours in any one day, or 40 hours in any one week, except in cases of necessity, emergency or when the public policy absolutely requires it, and in such cases, except in cases of contracts for personal services designated under ORS 279A.055, the employee shall be paid at least time and a half pay:
 - a) For all overtime in excess of eight hours a day or 40 hours in any one week when the work week is five consecutive days; or
 - b) For all overtime in excess of 10 hours in any one day or 40 hours in any one week when the work week is four consecutive days, Monday through Friday; and
 - c) For all work performed on Saturday and on any legal holiday specified in ORS 279B.020.

An employer must give notice in writing to employees who work on a public contract, either at the time of hire or before commencement of work on the contract, or by posting a notice in a location frequented by employees, of the number of hours per day and days per week that the employees may be required to work. ORS 279B.235(1)-(2).

- 8) If the agreement is for personal services, the contract shall contain a provision that the employee shall be paid at least time and a half for all overtime worked in excess of 40 hours in any one week, except for individuals under personal services contracts who are excluded under ORS 653.010 to 653.261 or under 29 U.S.C. 201-209 from receiving overtime. ORS 279B.235(3).
- 9) Contracts for services must contain a provision that requires that persons employed under contracts shall receive at least time and half pay for work performed on the legal holidays specified in a collective bargaining agreement or in ORS 279B.020(1)(b)(B)-(G) and for all time worked in excess of 10 hours in any one day or in excess of 40 hours in any one week, whichever is greater. Employer shall give notice in writing to employees who work on a contract for services, either at the time of hire or before commencement of work on the contract, or by posting a notice in a location frequented by employees, of the number hours per day and days per week that the employees may be required to work. ORS 279B.235(5).

If this agreement is for a public improvement, the contract shall contain the following conditions:

- 10) Make payment promptly, as due, to all persons supplying to the contractor labor or material for the performance of the work provided for in the contract. ORS 279C.505(1)(a).
- 11) Pay all contributions or amounts due the Industrial Accident Fund from the contractor or subcontractor incurred in the performance of the contract. ORS 279C.505(1)(b).
- 12) Not permit any lien or claim to be filed or prosecuted against the state or a county, school district, municipality, municipal corporation or subdivision thereof, on account of any labor or material furnished. ORS 279C.505(1)(c).
- 13) Pay to the Department of Revenue all sums withheld from employees under ORS 316.167. ORS 279C.505(1)(d).
- 14) The contractor shall demonstrate that an employee drug testing program is in place. ORS 279C.505(2).

- 15) If the contractor fails, neglects or refuses to make prompt payment of any claim for labor or services furnished to the contractor or subcontractor by any person in connection with the public improvement contract as the claim becomes due, the proper officer or officers representing the state or a county, school district, municipality, municipal corporation or subdivision thereof, as the case may be, may pay such claim to the person furnishing labor or services and charge the amount of the payment against the funds due or to become due the contract by reason of the contract. If the contractor or first-tier subcontractor fails, neglects or refuses to make payment to a person furnishing labor or materials in connection with the public improvement contract within 30 days after receipt of payment from the contracting agency or a contractor, the contractor or first-tier subcontractor shall owe the person the amount due plus interest charges commencing at the end of the 10-day period that payment is due under ORS 279C.580(4) and is subject to a good faith dispute as defined in ORS 279C.580. If the contractor or a subcontractor fails, neglects or refuses to make payment to a person furnishing labor or materials in connection with the public improvement contract, the person may file a complaint with the Construction Contractors Board, unless payment is subject to a good faith dispute as defined in ORS 279C.580. ORS 279C.515.
- 16) The payment of a claim does not relieve the contractor or the contractor's surety from obligation with respect to any unpaid claims. ORS 279C.515(4).
- 17) A person may not be employed for more than 10 hours in any one day, or 40 hours in any one week, except in cases of necessity, emergency or when the public policy absolutely requires it, and in such cases, except in cases of contracts for personal services designated under ORS 279C.100, the employee shall be paid at least time and a half pay:
 - a) For all overtime in excess of eight hours a day or 40 hours in any one week when the work week is five consecutive days; or,
 - b) For all overtime in excess of 10 hours in anyone day or 40 hours in any one week when the work week is four consecutive days, Monday through Friday; and,
 - c) For all work performed on Saturday and on any legal holiday specified in ORS 279B.020. ORS 279C.520(1).

An employer shall give notice in writing to employees who work on a public contract either at the time of hire or before commencement of work on the contract, or by posting a notice in a location frequented by employees, of the number of hours per day and days per week that the employees may be required to work. ORS 279B.520(2).

- 18) If the agreement is for personal services, the contract shall contain a provision that the employee shall be paid at least time and a half for all overtime worked in excess of 40 hours in any one week, except for individuals under personal services contracts who are excluded under ORS 653.010 to 653.261 or under 29 U.S.C. 201-209 from receiving overtime. ORS 279C.520(3).
- 19) Contracts for services must contain a provision that requires that persons employed under contracts shall receive at least time and half pay for work performed on the legal holidays specified in a collective bargaining agreement or in ORS 279C.540(1)(b)(B)-(G) and for all time worked in excess of 10 hours in any one day or in excess of 40 hours in any one week, whichever is greater. An employer shall give notice in writing to employees who work on a contract for services, either at the time of hire or before commencement of work on the contract, or by posting a notice in a location frequented by employees, of the number of hours per day and days per week that the employees may be required to work. ORS 279C.520(5)
- 20) ENVIRONMENTAL MATTERS: In compliance with ORS 279C.525, the Contractor is made aware that the following federal, state, and local agencies have enacted ordinances or regulations relating to the prevention of environmental pollution or the preservation of natural resources which may affect performance of SUB contracts. This is not intended to be a complete listing of agencies. Other agencies may have enacted ordinances or regulations that may apply.
 If the Contractor is delayed or must undertake additional work by reason of existing ordinances, rules or regulations of agencies not cited in the Contract or due to enactment of new or the amendment of existing statutes, ordinances, rules or regulations relating to the prevention of natural resources occurring after the submission of the successful quote, the contracting agency may, at its discretion, terminate the Contract, complete the work itself; use non-agency forces already under contract with the City, require that the underlying property owner be responsible for cleanup, solicit quotes for a new contractor to provide the necessary services or issue the Contractor a change order setting forth the additional work that must be undertaken.
 If the Contractor encounters a condition not referred to in the Invitation to Bid documents, not caused by the Contractor or any subcontractor employed on the project and not discoverable pre-bid visual site inspection, and the condition requires compliance with the ordinances, rules or regulations referred to under this regulation, the contractor shall immediately notify SUB of the condition.

FEDERAL AGENCIES

Department of Agriculture
 Forest Service
 Soil Conservation Service
 Department of the Army Corps of Engineers
 Coast Guard
 Department of Health and Human Services
 Department of the Interior
 Bureau of Indian Affairs
 Bureau of Land Management
 Bureau of Outdoor Recreation
 Department of Commerce

Fish and Wildlife Services
 Office of Surface Mining
 Reclamation and Enforcement
 Bureau of Reclamation
 Department of Labor
 Occupational Safety and Health Administration
 Mine Safety and Health Administration
 Department of Transportation
 Federal Highway Administration
 Environmental Protection Agency

STATE AGENCIES

Department of Agriculture
 Department of Energy

Department of Human Services
 Land Conservation and Development Commission

Department of Environmental Quality
Department of Fish and Wildlife
Department of Forestry
Department of Geology and Minerals

Division of State Lands
State Soil and Water Conservation Commission
Water Resources Department
Oregon Department of Transportation

LOCAL AGENCIES

Common Council, City of Springfield
Environmental Services, City of Springfield
Board of Commissioners, Lane County
Lane Regional Air Protection Agency
Willamalane Park & Recreation District
Rainbow Water District

Planning Commission, City of Springfield
Development Services Department, City of Springfield
Planning Commission, Lane County
Springfield Utility Board
Springfield Downtown & Glenwood Urban Renewal Districts

- 21) Promptly, as due, make payment to any person, copartnership, association or corporation furnishing medical, surgical and hospital care services or other needed care and attention, incident to sickness or injury, to the employees of the contractor, of all sums that the contractor agrees to pay for the services and all moneys and sums that the contractor collected or deducted from the wages of employees under any law, contract or agreement for the purpose of providing or paying for the services. All employers shall comply with ORS 656.017. ORS 279C.530.
- 22) A contract for public works shall contain a provision stating the existing state prevailing rate and wage and, if applicable, the federal prevailing rate of wage required. Every contract and subcontract shall contain a provision that workers shall be paid not less than the specified minimum hourly rate of wage in accordance with ORS 279C.838. ORS 279C.830(1).

If this agreement is for demolition, the contract shall also contain the following conditions:

- 23) Contractor must salvage or recycle construction and demolition debris, if feasible and cost-effective. ORS 279C.510(1)

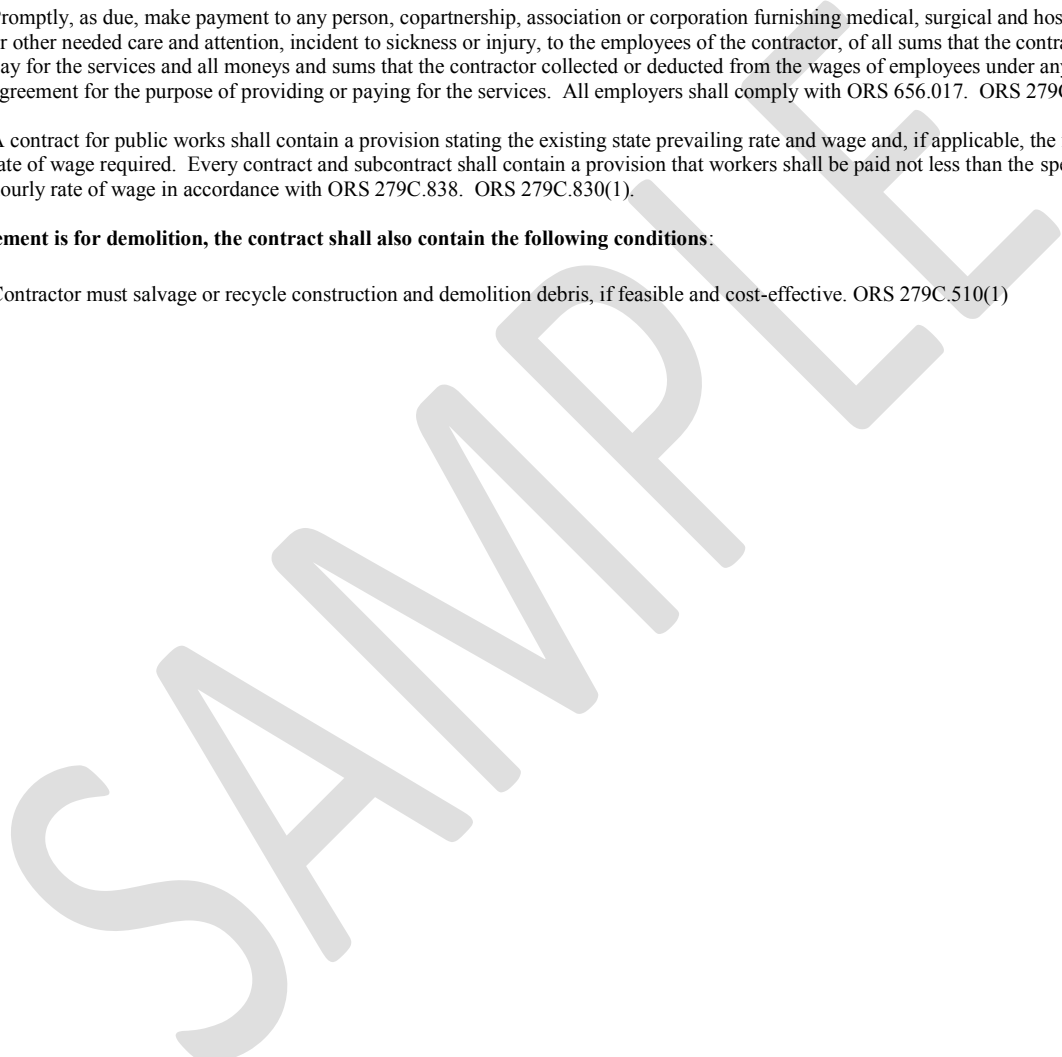

EXHIBIT "C"
OREGON TAX LAWS COMPLIANCE AND CERTIFICATION

A. Independent Contractor's Compliance with Tax Laws.

1. Independent Contractor must, throughout the duration of this Contract and any extensions, comply with all tax laws of this state and all applicable tax laws of any political subdivision of this state. For the purposes of this Section, "tax laws" includes all the provisions described in Subsection B. 3. (i) through (iv) of this Contract.

2. Any violation of Subsection 1 of this Section A shall constitute a material breach of this Contract. Further, any violation of Independent Contractor's warranty, in Subsection B.3. of this Contract, that Independent Contractor has complied with the tax laws of this state and the applicable tax laws of any political subdivision of this state also shall constitute a material breach of this Contract. Any violation shall entitle City to terminate this Contract, to pursue and recover any and all damages that arise from the breach and the termination of this Contract, and to pursue any or all of the remedies available under this Contract, at law, or in equity, including but not limited to:

- a. Termination of this Contract, in whole or in part;
- b. Exercise of the right of setoff, and withholding of amounts otherwise due and owing to Independent Contractor, in an amount equal to State's setoff right, without penalty; and
- c. Initiation of an action or proceeding for damages, specific performance, declaratory or injunctive relief. City shall be entitled to recover any and all damages suffered as the result of Independent Contractor's breach of this Contract, including but not limited to direct, indirect, incidental and consequential damages, costs of cure, and costs incurred in securing [replacement Services/replacement Goods/ a replacement Independent Contractor].

These remedies are cumulative to the extent the remedies are not inconsistent, and City may pursue any remedy or remedies singly, collectively, successively, or in any order whatsoever.

B. Independent Contractor's Representations and Warranties.

Independent Contractor represents and warrants to City that:

1. Independent Contractor (to the best of Independent Contractor's knowledge, after due inquiry), for a period of no fewer than six calendar years preceding the [date of Closing of {bids/proposals}/effective date of] this Contract, faithfully has complied with:

- (i) All tax laws of this state, including but not limited to ORS 305.620 and ORS chapters 316, 317, and 318;
- (ii) Any tax provisions imposed by a political subdivision of this state that applied to Independent Contractor, to Independent Contractor's property, operations, receipts, or income, or to Independent Contractor's performance of or compensation for any work performed by Independent Contractor;
- (iii) Any tax provisions imposed by a political subdivision of this state that applied to Independent Contractor, or to goods, services, or property, whether tangible or intangible, provided by Independent Contractor; and
- (iv) Any rules, regulations, charter provisions, or ordinances that implemented or enforced any of the foregoing tax laws or provisions.

Any [Goods/Items/Equipment/Components/Hardware/Software/Intellectual Property Rights, etc.] [delivered to/granted to] City under this Contract, and Independent Contractor's Services rendered in the performance of Independent Contractor's obligations under this Contract, shall be provided to City free and clear of any and all restrictions on or conditions of use, transfer, modification, or assignment, and shall be free and clear of any and all liens, claims, mortgages, security interests, liabilities, charges, and encumbrances of any kind.

Minority, Women, and Emerging Small Business/Disadvantaged Business Enterprise



MWESB/DBE Voluntary Self-Declaration for City Procurement # _____ or Project No. P _____

The Public Works Department of the City of Springfield is seeking information on the various business entities that submit bids and proposals for working with the Department. We request that you provide the following information to assist us with evaluating our efforts at reaching the underrepresented sectors of the business and construction communities. The Department does not intend to use this data as criteria for selecting the successful bidders or proposers for city-funded procurements. For procurements with state or federal DBE requirements, the Department will use the forms and criteria established by the state or federal agency for selecting the successful bidders or proposers.

Please include this form with your bid/proposal submittal to the City.

Prime Bidder/Proposer: _____

Business Name: _____

Contact Person: _____

CCB#/PE#/Other Registration: _____

Business Address: _____

Business Phone: _____

Please check each box indicating the business certification type that your firm has with the State of Oregon or the federal government, if any:

- Oregon Minority-owned Business
- Oregon Woman-owned Business
- Oregon Emerging Small Business
- Federal Disadvantaged Business Enterprise (DBE)

First Tier Sub-contractors:

For each First Tier Subcontractor, provide the same information, using additional sheets as necessary: